

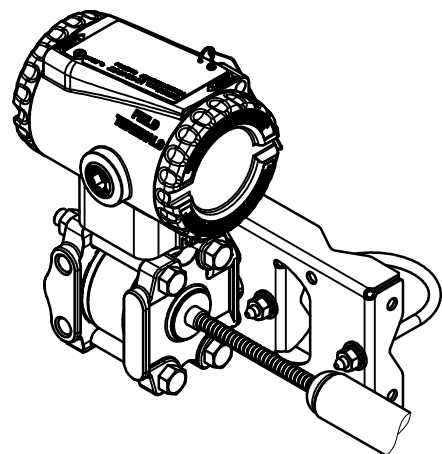

REV. 1-ALTER. SUPORTE - ALT-DM-0087/2008  
 REV. 2-ALTER. GEOMETRIA FLANGES DO TRANSMISSOR - ALT-DD-0016/2010  
 REV. 3-ALTER. TITULO E GEOMETRIA FLANGES - ALT-0440/14

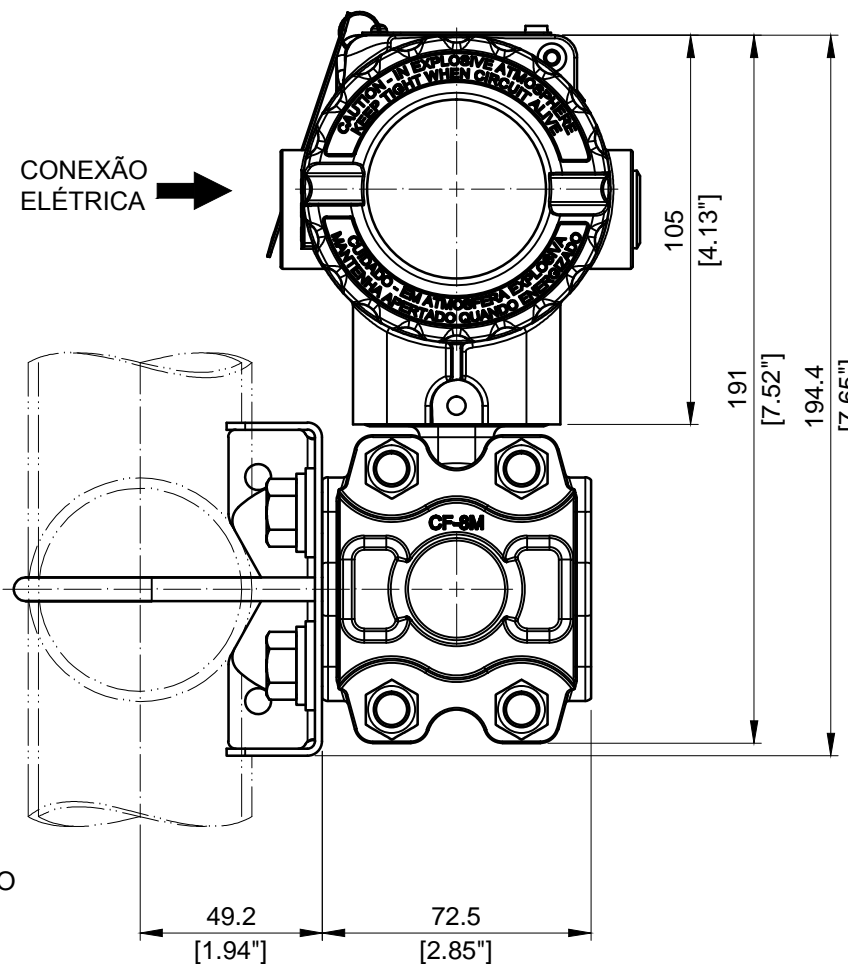
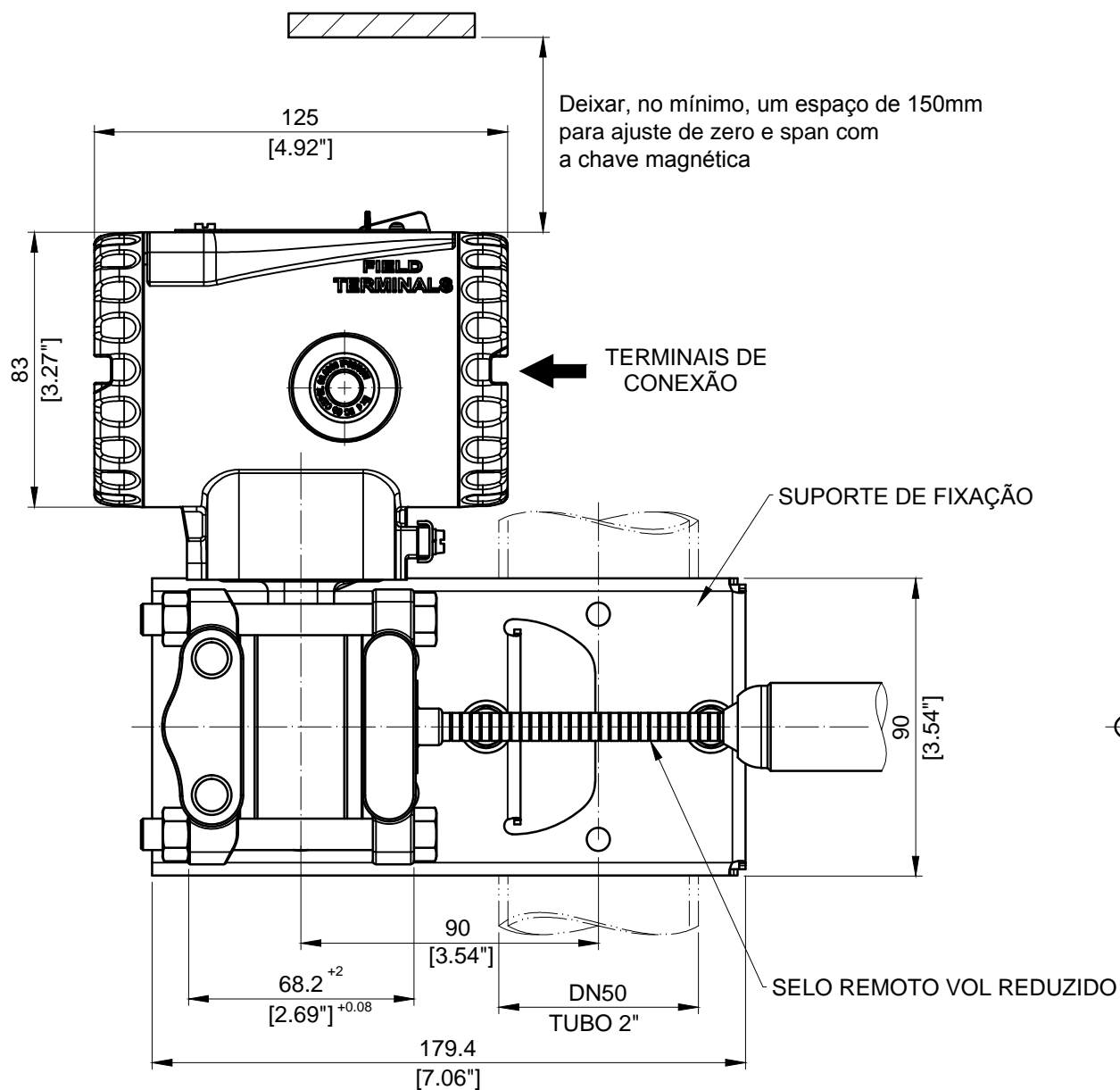

NOTAS:  
 AS DIMENSÕES SÃO EM mm (POLEGADAS)

REV	PROJETO	APROVAÇÃO	AREA	DESENHO	PROJETO	VERIFIC.	APROVAÇÃO	 OS DESENHO N° <b>101-B-5412-03</b> ESC 1:2   FL /
3	GUSKA 28 / 08 / 2014	P.MISAWA 12 / 03 / 2015	GERAL	EDNA	EDNA	GUSKA	P.MISAWA	
2	GUSKA 05 / 04 / 2010	P.MISAWA 05 / 04 / 2010	GERAL	CLIENTE				
1	GUSKA 25 / 08 / 2008	P.MISAWA 25 / 08 / 2008	GERAL	EQUIPAMENTO LD400 SERIES				
				DESENHO DIMENSIONAL LD400A/M - SELO VOLUME REDUZIDO				