

REV. 1-ALTER. GEOMETRIA FLANGES DO TRANSMISSOR - ALT-DD-0016/2010
 REV. 2-ALTER. TITULO E GEOMETRIA FLANGES - ALT-0440/14

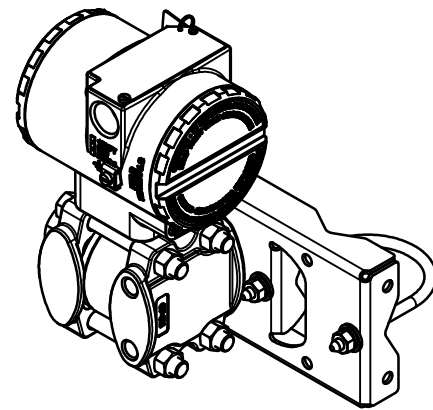
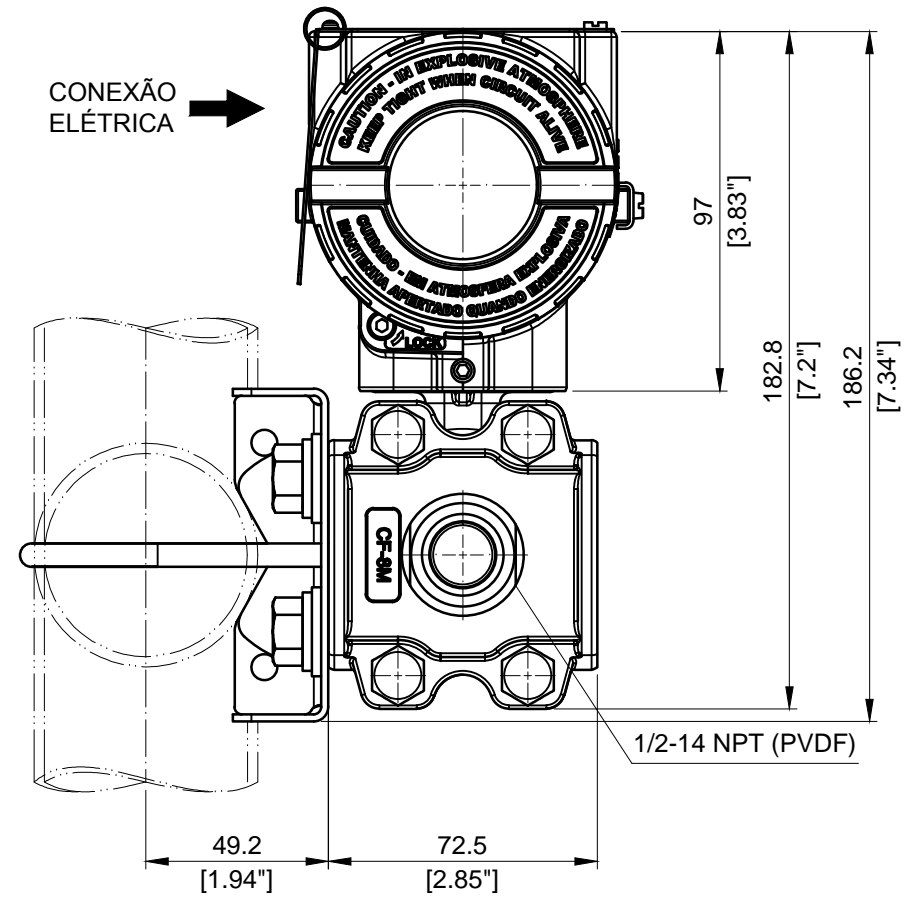
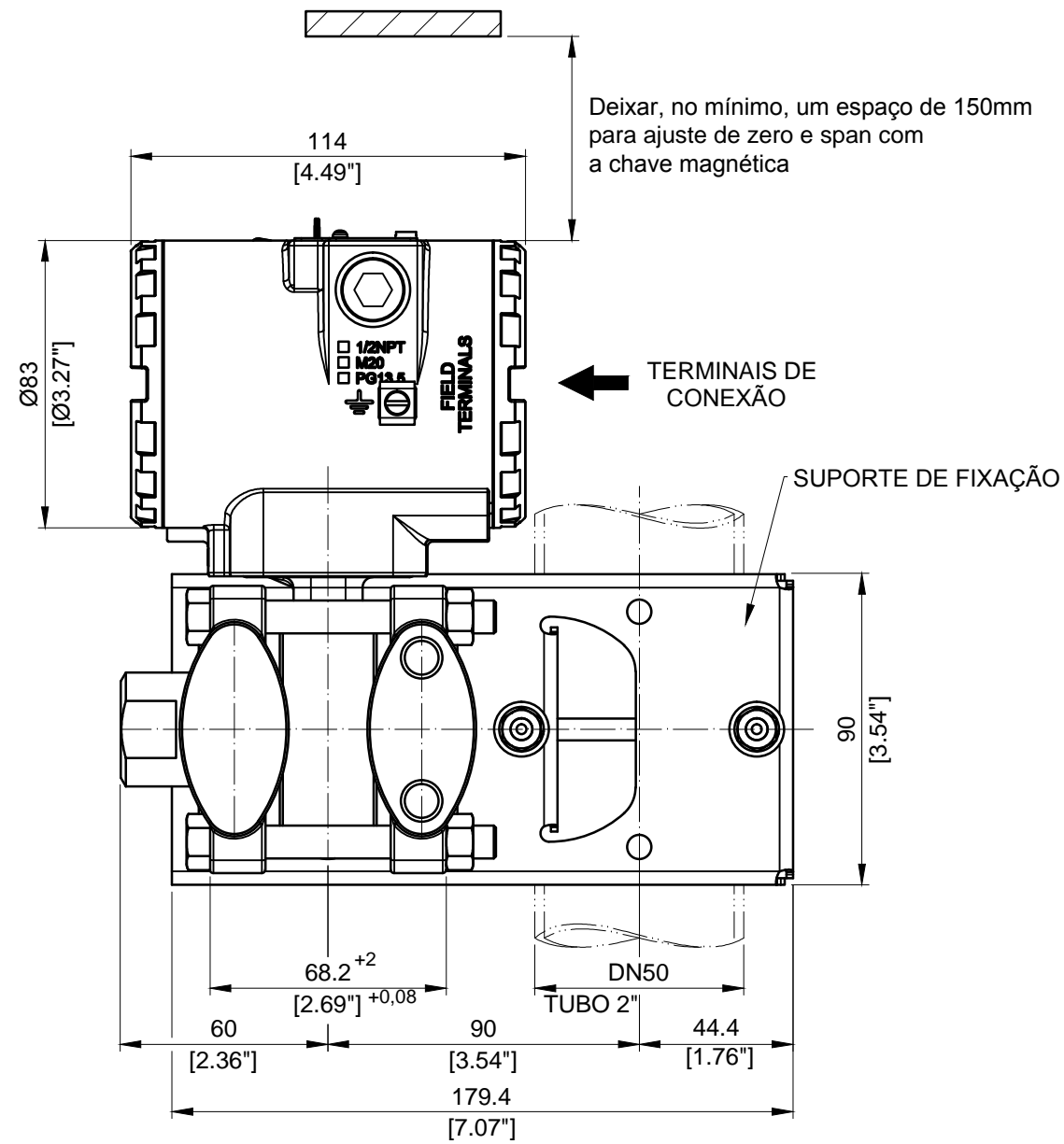

NOTAS:
 AS DIMENSÕES SÃO EM mm (POLEGADAS)

				DESENHO	PROJETO	VERIFIC.	APROVAÇÃO	smar
				GUSKA	GUSKA	EDNA	P.MISAWA	
				20 / 08 / 2008	20 / 08 / 2008	20 / 08 / 2008	20 / 08 / 2008	OS
2	GUSKA	P.MISAWA	GERAL	CLIENTE				DESENHO N°
	27 / 08 / 2014	11 / 03 / 2015		EQUIPAMENTO LD300 SERIES				101-B-6287-02
1	GUSKA	P.MISAWA	GERAL	DESENHO DIMENSIONAL				ESC 1:2
	05 / 04 / 2010	05 / 04 / 2010		LD30XA / M - 1/2 NPT PVDF (KYNAR)				FL /
REV	PROJETO	APROVAÇÃO	AREA					