

**MANUAL**

INSTALLATION | OPERATION | MAINTENANCE

# TRIPLE CHANNEL CURRENT TO PROFIBUS CONVERTER IF303



DEC/24 - VERSION 3

**smar**  
Technology Company

# IF303

Triple Channel Current to Profibus Converter



Consult our subsidiary



Rua Dr. Antônio Furlan Junior, 1028 - Sertãozinho, SP - CEP: 14170-480  
insales@smar.com.br | +55 (16) 3946-3599 | www.smar.com

© Copyright 2024, Nova Smar S/A. All rights reserved. December 2024.  
Specifications and information are subject to change.  
Updated addresses are available on our website.

**smar**  
Technology Company



# INTRODUCTION

The **IF303** is a converter mainly intended to interface analog transmitters to a Profibus PA network. The **IF303** receives up to three current signal typically 4-20 mA or 0-20 mA, and makes them available to Profibus PA system. The digital technology used in the **IF303** enables an easy interface between the field and the control room and it has several interesting features that reduce considerably the installation, operation and maintenance costs.

The **IF303** is part of SMAR's complete 303 line of Profibus PA devices.

Profibus PA, is not only a replacement for 4-20 mA or intelligent/smart transmitter protocols, it contains much more.

The digital technology used in the **IF303** enables the choice of several types of transfer functions, an easy interface between the field and the control room and several interesting features that considerably reduce the installation, operation and maintenance costs.

Some of the advantages of bi-directional digital communications are known from existing smart transmitter protocols: Higher accuracy, multi-variable access, remote configuration and diagnostics, and multi-dropping of several devices on a single pair of wires.

The system controls variable sampling, algorithm execution and communication so as to optimize the usage of the network, not losing time. Thus, high closed loop performance is achieved.

Using Profibus technology, with its capability to interconnect several devices, very large control schemes can be constructed. In order too be user friendly the function block concept was introduced

The **IF303**, like the rest of the 303 family, has some Function Blocks built in, like Analog Input and Totalizer Blocks.

The need for implementation of Fieldbus in small as well as large systems was considered when developing the entire 303 line of Profibus-PA devices. They have common features and can be configured locally using a magnetic tool, eliminating the need for a configuration tool or console in many basic applications.

**Get the best result of the IF303 by carefully reading these instructions.**

## NOTE

**In case of using Simatic PDM as the configuration and parameterization tool, Smar recommends that the user does not apply the option "Download to Device". This function can improperly configure the field device. Smar recommends that user make the use of the option "Download to PG / PC" and then selecting the Device Menu, use the menus of the transducer, function and display blocks acting specifically, according to each menu and method for reading and writing.**

This product is protected by US patent number **5,706,007**.

**NOTE**

This Manual is compatible with version 3.XX, where 3 denotes software version and XX software release. The indication 3.XX means that this manual is compatible with any release of software version 3.

**Waiver of responsibility**

The contents of this manual abides by the hardware and software used on the current equipment version. Eventually there may occur divergencies between this manual and the equipment. The information from this document are periodically reviewed and the necessary or identified corrections will be included in the following editions. Suggestions for their improvement are welcome.

**Warning**

For more objectivity and clarity, this manual does not contain all the detailed information on the product and, in addition, it does not cover every possible mounting, operation or maintenance cases.

Before installing and utilizing the equipment, check if the model of the acquired equipment complies with the technical requirements for the application. This checking is the user's responsibility.

If the user needs more information, or on the event of specific problems not specified or treated in this manual, the information should be sought from Smar. Furthermore, the user recognizes that the contents of this manual by no means modify past or present agreements, confirmation or judicial relationship, in whole or in part.

All of Smar's obligation result from the purchasing agreement signed between the parties, which includes the complete and sole valid warranty term. Contractual clauses related to the warranty are not limited nor extended by virtue of the technical information contained in this manual.

Only qualified personnel are allowed to participate in the activities of mounting, electrical connection, startup and maintenance of the equipment. Qualified personnel are understood to be the persons familiar with the mounting, electrical connection, startup and operation of the equipment or other similar apparatus that are technically fit for their work. Smar provides specific training to instruct and qualify such professionals. However, each country must comply with the local safety procedures, legal provisions and regulations for the mounting and operation of electrical installations, as well as with the laws and regulations on classified areas, such as intrinsic safety, explosion proof, increased safety and instrumented safety systems, among others.

The user is responsible for the incorrect or inadequate handling of equipments run with pneumatic or hydraulic pressure or, still, subject to corrosive, aggressive or combustible products, since their utilization may cause severe bodily harm and/or material damages.

The field equipment referred to in this manual, when acquired for classified or hazardous areas, has its certification void when having its parts replaced or interchanged without functional and approval tests by Smar or any of Smar authorized dealers, which are the competent companies for certifying that the equipment in its entirety meets the applicable standards and regulations. The same is true when converting the equipment of a communication protocol to another. In this case, it is necessary sending the equipment to Smar or any of its authorized dealer. Moreover, the certificates are different and the user is responsible for their correct use.

Always respect the instructions provided in the Manual. Smar is not responsible for any losses and/or damages resulting from the inadequate use of its equipments. It is the user's responsibility to know and apply the safety practices in his country.

# TABLE OF CONTENTS

<b>SECTION 1 - INSTALLATION .....</b>	<b>1.1</b>
GENERAL .....	1.1
MOUNTING .....	1.1
ELECTRIC WIRING .....	1.1
TOPOLOGY AND NETWORK CONFIGURATION .....	1.3
INTRINSIC SAFETY BARRIER .....	1.4
JUMPER CONFIGURATION .....	1.5
POWER SUPPLY .....	1.5
INPUT WIRING .....	1.5
INSTALLATION IN HAZARDOUS AREAS .....	1.7
EXPLOSION/FLAME PROOF .....	1.7
INTRINSICALLY SAFE .....	1.7
<b>SECTION 2 - OPERATION .....</b>	<b>2.1</b>
FUNCTIONAL DESCRIPTION – ELECTRONICS .....	2.1
<b>SECTION 3 - CONFIGURATION .....</b>	<b>3.1</b>
TRANSDUCER BLOCK .....	3.1
HOW TO CONFIGURE A TRANSDUCER BLOCK .....	3.1
TERMINAL NUMBER .....	3.1
FUNCTIONAL DIAGRAM OF THE CURRENT TO PROFIBUS PA TRANSDUCER BLOCK .....	3.2
CURRENT TO PROFIBUS PA TRANSDUCER BLOCK GENERAL PARAMETER DESCRIPTION .....	3.2
TRANSDUCER BLOCK PARAMETER ATTRIBUTES .....	3.4
IF303 - CYCLIC CONFIGURATION .....	3.5
HOW TO CONFIGURE THE ANALOG INPUT BLOCK .....	3.9
HOW TO CONFIGURE THE TOTALIZER BLOCK .....	3.12
CURRENT TRIM .....	3.16
VIA LOCAL ADJUSTMENT .....	3.19
TRANSDUCER DISPLAY – CONFIGURATION .....	3.20
DISPLAY TRANSDUCER BLOCK .....	3.21
DEFINITION OF PARAMETERS AND VALUES .....	3.21
PROGRAMMING USING LOCAL ADJUSTMENT .....	3.26
QUICK GUIDE – LOCAL ADJUSTMENT TREE .....	3.28
J1 JUMPER CONNECTIONS .....	3.29
W1 JUMPER CONNECTIONS .....	3.29
CYCLICAL DIAGNOSIS .....	3.31
<b>SECTION 4 - MAINTENANCE PROCEDURES .....</b>	<b>4.1</b>
GENERAL .....	4.1
TROUBLESHOOTING .....	4.1
DISASSEMBLY PROCEDURE .....	4.2
REASSEMBLY PROCEDURE .....	4.2
BOARDS INTERCHANGEABILITY .....	4.3
EXPLODED VIEW .....	4.3
ACCESSORIES AND RELATED PRODUCTS .....	4.3
SPARE PARTS LIST .....	4.4
<b>SECTION 5 - TECHNICAL CHARACTERISTICS .....</b>	<b>5.1</b>
ORDERING CODE .....	5.2
<b>APPENDIX A - CERTIFICATIONS INFORMATION .....</b>	<b>A.1</b>
<b>APPENDIX B – SRF – SERVICE REQUEST FORM .....</b>	<b>B.1</b>

**Installation Flowchart**

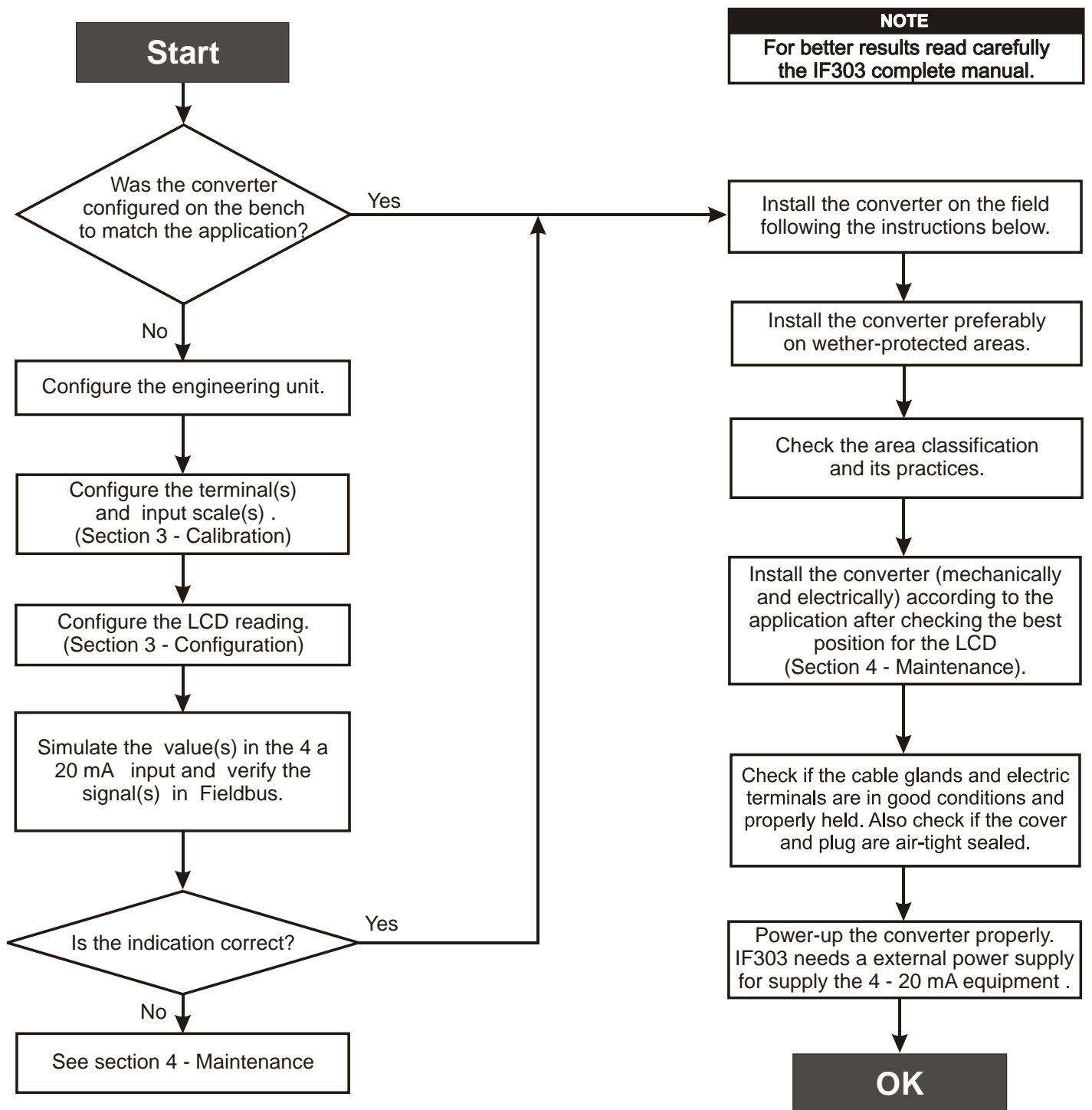

# Section 1

---

## INSTALLATION

### General

NOTE
The installation carried out in hazardous areas should follow the recommendations of the IEC60079-14 standard.

The overall accuracy of measurement and control depends on several variables. Although the converter has an outstanding performance, proper installation is essential, in order to maximize its performance.

Among all factors, which may affect converter accuracy, environmental conditions are the most difficult to control. There are, however, ways of reducing the effects of temperature, humidity and vibration.

Locating the converter in areas protected from extreme environmental changes can improve the converter performance.

In warm environments, the converter should be installed to avoid as much as possible, direct exposure to the sun. Installation close to lines and vessels subjected to high temperatures should also be avoided.

Use of sunshades or heat shields to protect the converter from external heat sources should be considered, if necessary.

Humidity is fatal to electronic circuits. In areas subjected to high relative humidity, the O-rings for the electronics cover must be correctly placed. Removal of the electronics cover in the field should be reduced to the minimum necessary, since each time it is removed the circuits are exposed to the humidity. The electronic circuit is protected by a humidity proof coating, but frequent exposures to humidity may affect the protection provided. It is also important to keep the covers tightened in place. Every time they are removed, the threads are exposed to corrosion, since painting cannot protect these parts. Code-approved sealing methods on conduit entering the converter should be employed.

### Mounting

Using the bracket, the mounting may be done in several positions, as shown on Figure 1.3 - Dimensional Drawing and Mounting Positions.

For better visibility, the digital indicator may be rotated in steps of 90° (See Section 4 - Maintenance Procedures).

### Electric Wiring

Access the wiring block by removing the Electrical Connection Cover. This cover can be locked closed by the cover locking screw (See Figure 1.1 - Cover Locking) To release the cover, rotate the locking screw clockwise.

Cable access to wiring connections is obtained by one of the two conduit outlets. Conduit threads should be sealed by means of code-approved sealing methods. The unused outlet connection should be plugged accordingly.

The wiring block has screws, on which fork or ring type terminals can be fastened, see Figure 1.2 - Terminal Block.

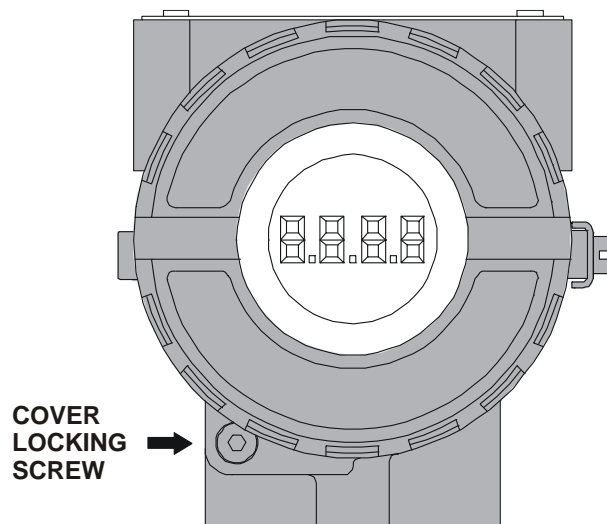

**Figure 1.1 - Cover Locking**

For convenience there are three ground terminals: one inside the cover and two externals, located close to the conduit entries.

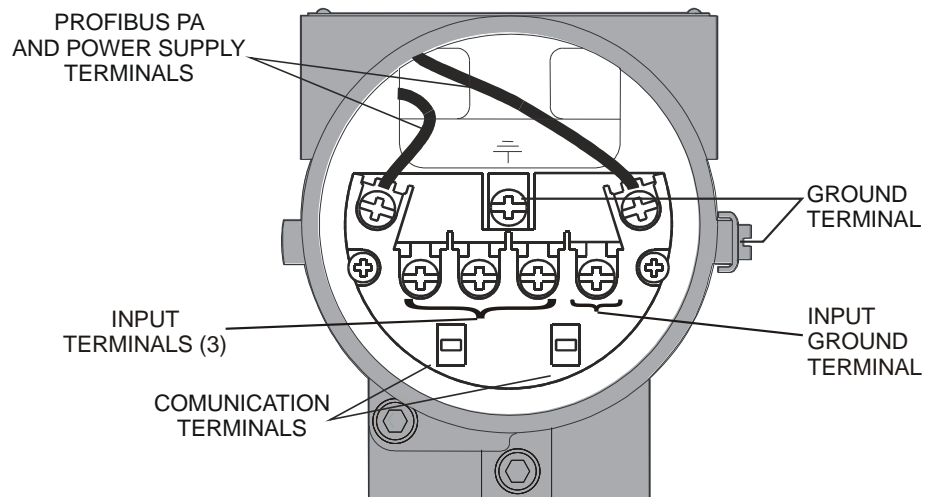

**Figure 1.2 - Terminal Block**

The **IF303** uses the 31.25 kbit/s voltage mode option for the physical signaling. All other devices on the same bus must use the same signaling.

Various types of Fieldbus devices may be connected on the same bus.

The **IF303** is powered via the bus. The limit for such devices is according to the DP/PA coupler limitations for one bus (one segment) for non-intrinsically safe requirement.

In hazardous area, the number of devices may be limited by intrinsically safe restrictions, according to the DP/PA coupler and barriers limitations.

The **IF303** is protected against reverse polarity, and can withstand  $\pm 35$  VDC without damage, but it will not operate when in reverse polarity.

**NOTE**

Please refer to the General Installation, Operation and Maintenance Procedures Manual for more details.



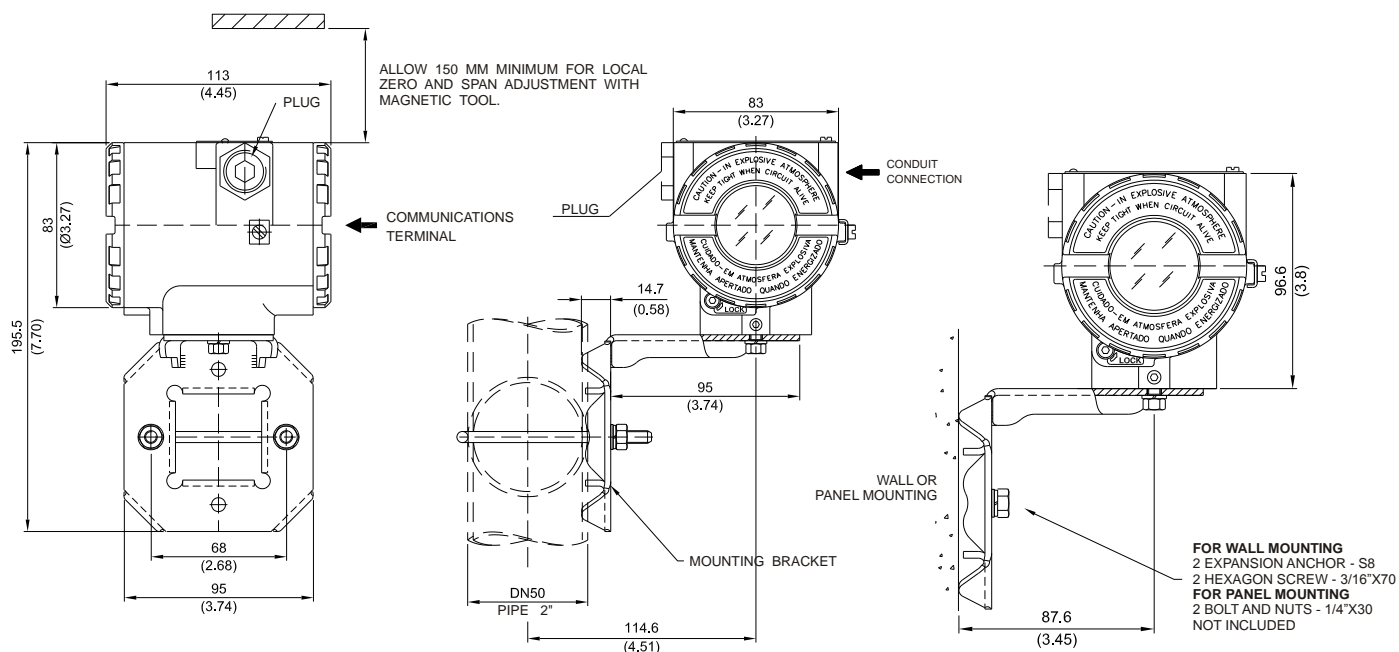

Figure 1.3 - Dimensional Drawing and Mounting Positions

## Topology and Network Configuration

Bus topology (See Figure 1.4 - Bus Topology) and tree topology (See Figure 1.5 - Tree Topology) are supported. Both types have a trunk cable with two terminations. The devices are connected to the trunk via spurs. The spurs may be integrated in the device giving zero spur length. A spur may connect more than one device, depending on the length. Active couplers may be used to extend spur length.

Active repeaters may be used to extend the trunk length.

The total cable length, including spurs, between any two devices in the Fieldbus should not exceed 1900m.

The connection of couplers should be kept less than 15 per 250m. In following figures DP/PA link depends on the application needs.

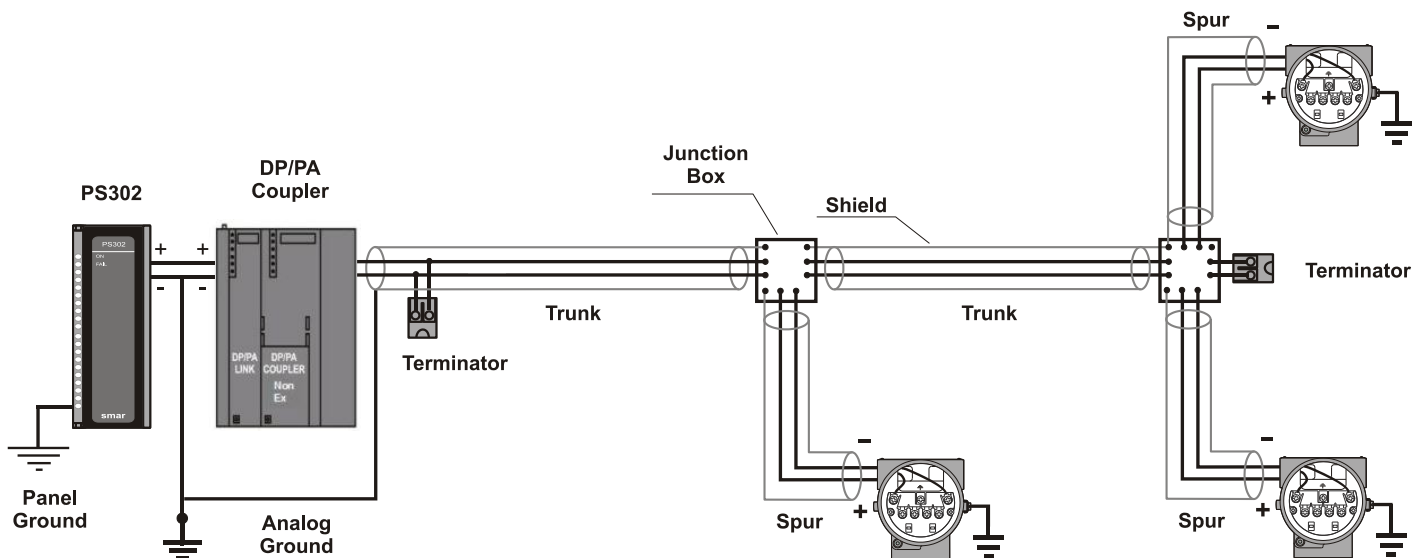

Figure 1.4 - Bus Topology

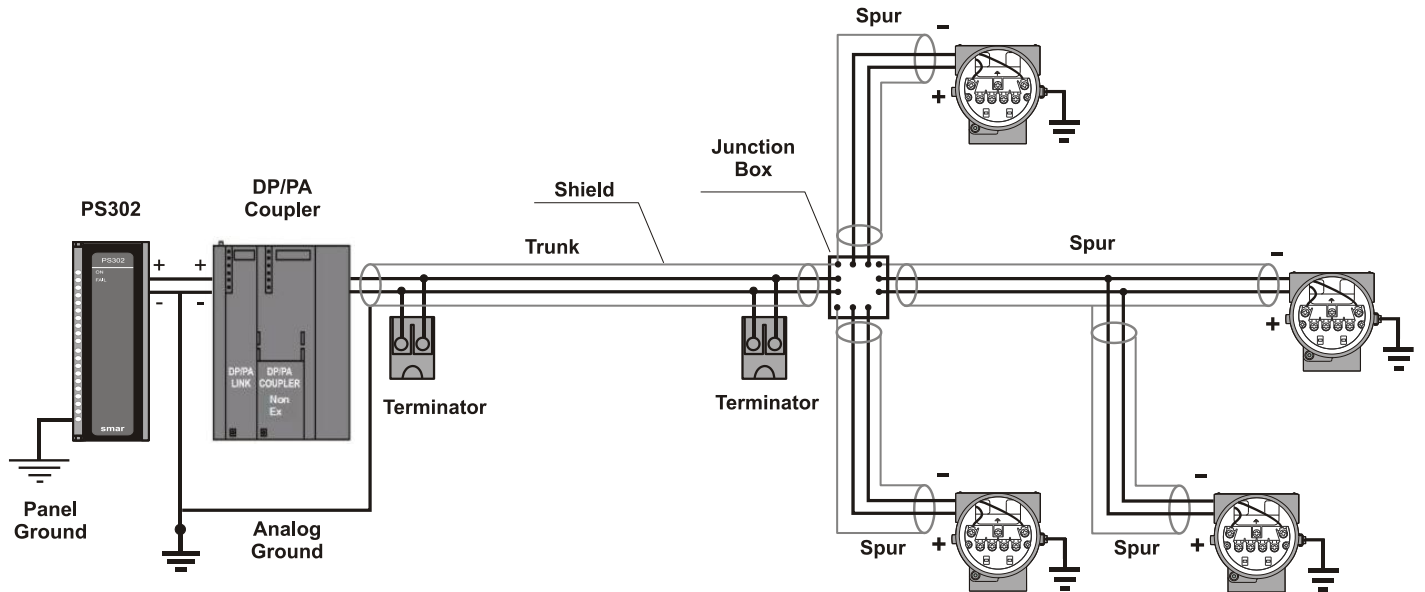

Figure 1.5 - Tree Topology

## Intrinsic Safety Barrier

When the Fieldbus is in an area requiring intrinsic safety, a barrier must be inserted on the trunk between the power supply and the DP/PA coupler, when it is Non-Ex type.

Use of **DF47** is recommended.

## Jumper Configuration

In order to work properly, the jumpers J1 and W1 located in the **IF303** main board must be correctly configured (See Table 1.1 - Description of the Jumpers).

<b>J1</b>	This jumper enables the simulation mode parameter in the AI block.
<b>W1</b>	This jumper enables the local adjustment programming tree.

Table 1.1 - Description of the Jumpers

## Power Supply

The **IF303** receives power from the bus via the signal wiring. The power supply may come from a separate unit or from another device such as a controller or DCS.

The voltage should be between 9 to 32 Vdc for non-intrinsic safe applications.

A special requirement applies to the power supply used in an intrinsically safe bus and depends on the type of barrier used.

Use of **PS302** is recommended as power supply.

## Input Wiring

The **IF303** accepts up to three current inputs in the range 0-20 mA or 4-20 mA. The three inputs have a common ground and they are protected from reverse polarity signal. The inputs should be connected as per Figure 1.6 - Input Wiring.

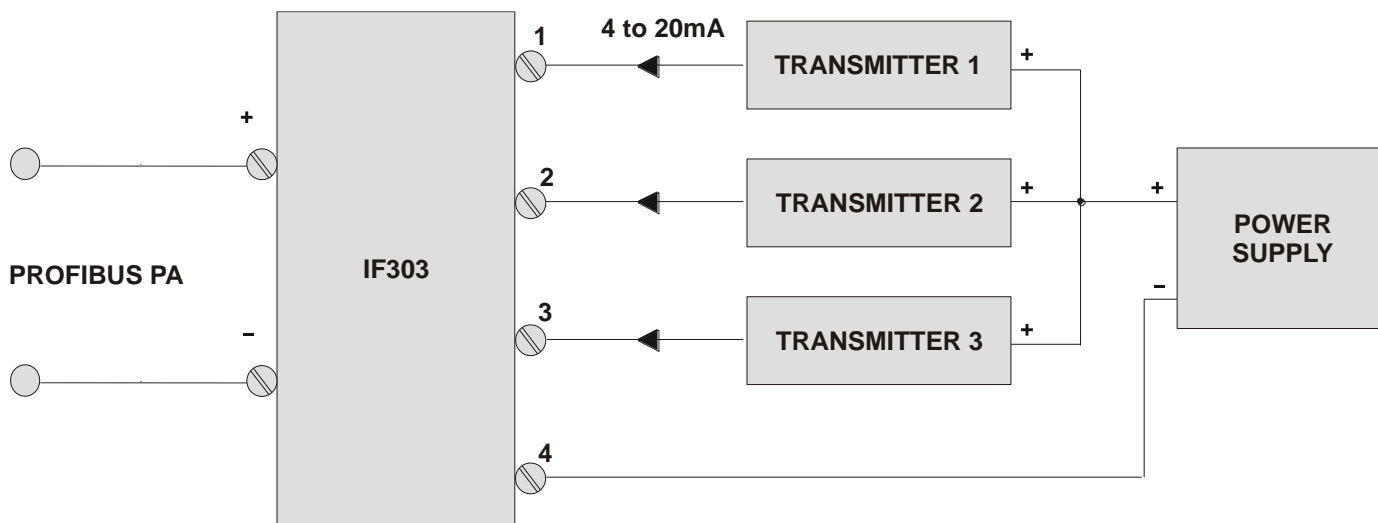

Figure 1.6 - Input Wiring

Note that **IF303** can operate with 0-20 mA or 4-20mA transmitters (See Figure 1.7 - Connection).

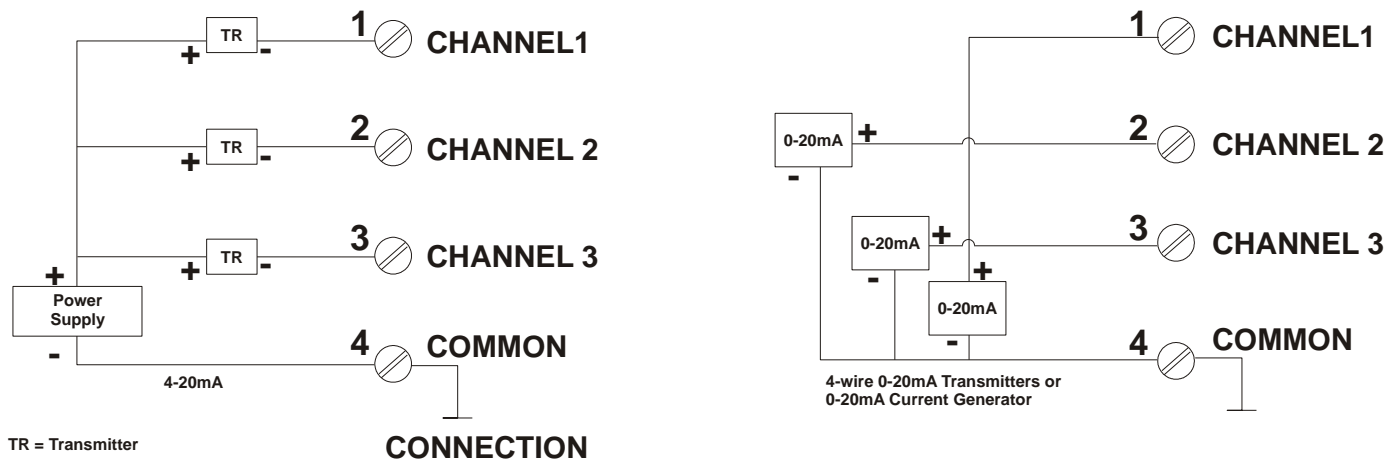

Figure 1.7 - Connection

Avoid routing input wiring close to power cables or switching equipment.

### WARNING

Apply in the inputs of the converter only current levels. Don't apply tension levels, because the shunt resistors are of 100R 1W and tension above 10 Vdc it can damage them.

## Installation in Hazardous Areas

### WARNING

Explosions could result in death or serious injury, besides financial damage. Installation of this converter in explosive areas must be carried out in accordance with the local standards and the protection type adopted. Before continuing the installation make sure the certificate parameters are in accordance with the classified area where the equipment will be installed.

The instrument modification or parts replacement supplied by other than authorized representative of Smar is prohibited and will void the certification.

The converters are marked with options of the protection type. The certification is valid only when the protection type is indicated by the user. Once a particular type of protection is selected, any other type of protection can not be used.

The electronic housing and the sensor installed in hazardous areas must have a minimum of 6 fully engaged threads. Lock the housing using the locking screw (Figure 1.1).

The cover must be tightened with at least 8 turns to avoid the penetration of humidity or corrosive gases. The cover must be tightened until it touches the housing. Then, tighten more 1/3 turn (120°) to guarantee the sealing. Lock the covers using the locking screw (Figure 1.1).

Consult the Appendix A for further information about certification.

## Explosion/Flame Proof

### WARNING

In Explosion-Proof installations the cable entries must be connected or closed using metal cable gland and metal blanking plug, both with at least IP66 and Ex-d certification.

The standard plugs provided by Smar are certified according to CEPEL certificate. If the plug needs to be replaced, a certified plug must be used.

The electrical connection with NPT thread must use waterproofing sealant. A non-hardening silicone sealant is recommended.

For NEMKO ATEX certificate please to follow the installation guidelines in hazardous locations below: Group II Category 2G, Ex d, Group IIC, Temperature Class T6, EPL Gb U = 28VDC  
Ambient Temperature: -20 to 60°C for T6

Environmental Protection: IP66/687 or IP66W/687W

The electrical connection available are ½ - 14NPT and M20x1,5.

Cable entries must be connected or closed using metal cable gland and metal blanking plug, both with at least IP66 and Ex-d certification or any appropriate ATEX approved metal cable gland and metal blanking plug. Do not remove the transmitter covers when power is ON.

## Intrinsically Safe

### WARNING

In hazardous zones with intrinsically safe or non-incendive requirements, the circuit entity parameters and applicable installation procedures must be observed.

To protect the application the transmitter must be connected to a barrier. Match the parameters between barrier and the equipment (Consider the cable parameters). Associated apparatus ground bus shall be insulated from panels and mounting enclosures. Shield is optional. If used, be sure to insulate the end not grounded. Cable capacitance and inductance plus  $C_i$  and  $L_i$  must be smaller than  $C_o$  and  $L_o$  of the associated Apparatus.

It is not recommended to remove the transmitter cover when the power is ON.

# OPERATION

The **IF303** accepts signals from mA generators such as most conventional transmitters. It is therefore ideal for interfacing existing equipment to a Fieldbus system.

## ***Functional Description – Electronics***

See Figure 2.2 - IF303 Block Diagram. The function of each block is described below.

### **MUX Multiplexer**

The MUX multiplexes the input terminals to ensure that all three channels reach the A/D converter.

### **A/D Converter**

The A/D converts the input signals to a digital format for the CPU.

### **Signal Isolator**

Its function is to isolate the data signal between the input and the CPU.

### **(CPU) Central Processing Unit, RAM and FLASH**

The CPU is the intelligent portion of the converter, being responsible for the management and operation of block execution, self-diagnostics and communication. The program is stored in Flash memory. For temporary storage of data there is a RAM. The data in the RAM is lost if the power is switched off, however the device also has a nonvolatile EEPROM where data that must be retained are stored. Examples of such data are: calibration, configuration and identification data.

### **Communication Controller**

It monitors line activity, modulates and demodulates the signal from network line.

### **Power Supply**

Takes power of the loop-line to power the converter circuitry.

### **Power Isolation**

Just like the signals from the input section, the power to the input section must be isolated.

### **Display Controller**

Receives data from the CPU and drives the Liquid Crystal Display.

### **Local Adjustment**

They are two switches that are magnetically activated. They can be activated by the magnetic tool without mechanical or electrical contact.

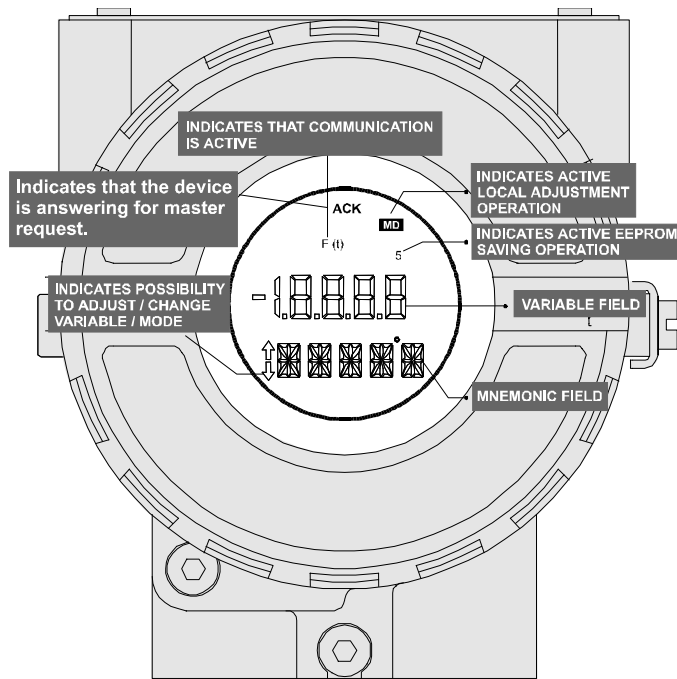

Figure 2.1 - LCD Indicator

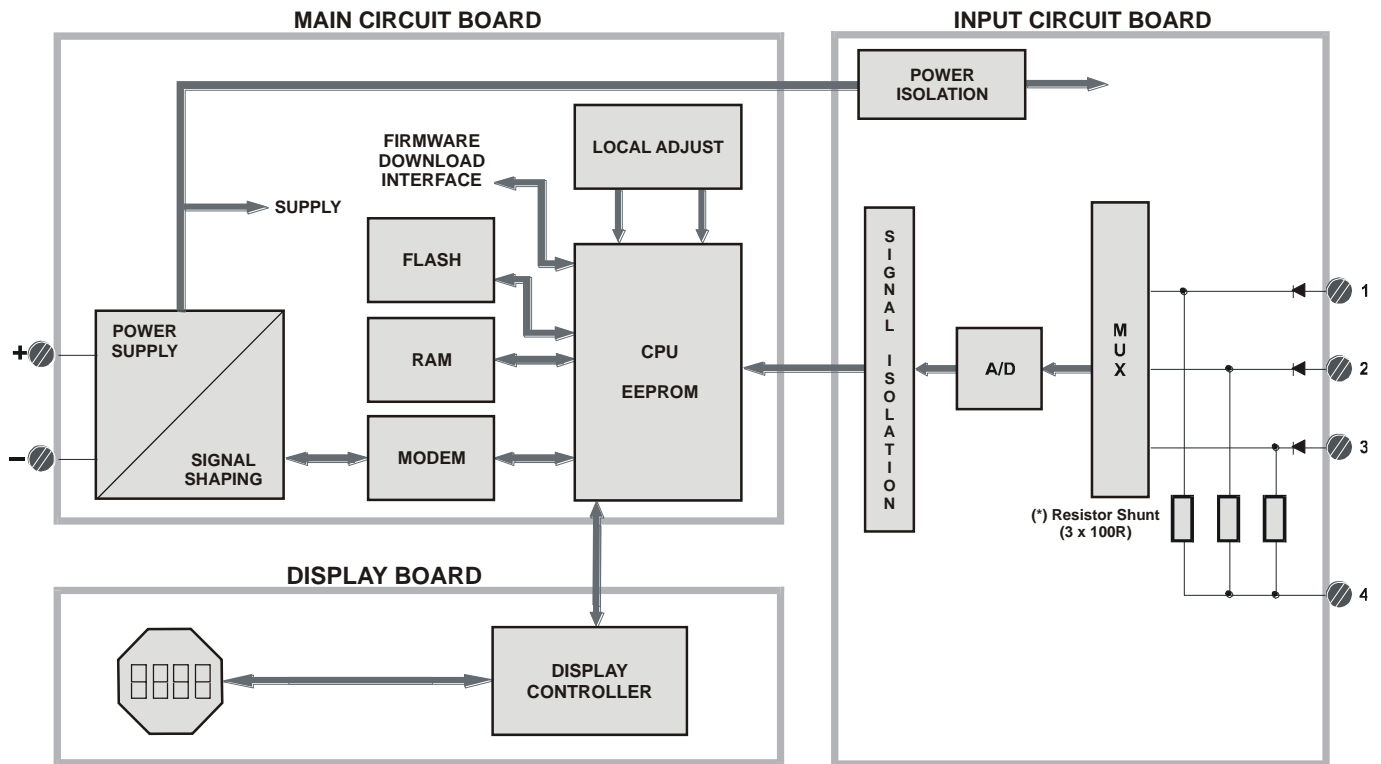

Figure 2.2 - IF303 Block Diagram

**WARNING**

Apply in the inputs of the converter only current levels. **Don't apply tension levels**, because the shunt resistors are of 100R 1W and **tension higher than 10 Vdc can damage them.**

## CONFIGURATION

One of the many advantages of using Fieldbus technologies is that device configuration is independent of the configuration software. The **IF303** may be configured by a third party terminal or operator console as Smar's configurators ProfibusView or AssetView for FDT.

The **IF303** contains three input transducer blocks, one physical block, one display transducer block, three analog input and three totalizer function blocks.

Function Blocks are not covered in this manual. For further explanation and details of function blocks, see the "Function Blocks Manual".

In order to assure correct values in the offline configuration, when using download function of Simatic PDM, please make sure you have done the upload firstly.

### Offline Configuration

1. First run "Download to PG/PC" option to assure valid values.
2. Run after the Menu Device option to configure the required parameters using the related menus.

NOTE
It is not advisable to use the "Download to Device" option. This function can misconfigure the equipment.

## Transducer Block

Transducer block insulates function block from the specific I/O hardware, such as sensors and actuators. Transducer block controls access to I/O through manufacturer specific implementation. This permits the transducer block to execute as frequently as necessary to obtain good data from sensors without burdening the function blocks that use the data. It also insulates the function blocks from the manufacturer specific characteristics of certain hardware.

By accessing the hardware, the transducer block can get data from I/O or passing control data to it. The connection between Transducer block and Input/Output Function blocks is called channel. Normally, transducer blocks perform functions, such as linearization, characterization, temperature compensation, control and exchange data to/from hardware.

## How to Configure a Transducer Block

The transducer block has an algorithm, a set of contained parameters and a channel connecting it to a function block. The algorithm describes the behavior of the transducer as a data transfer function between the I/O hardware and other function block. The set of contained parameters, it means, you are not able to link them to other blocks, defines the user interface to the transducer block. They can be divided into Standard and Manufacturer Specific.

The standard parameters will be present for such class of device, as pressure, temperature, actuator, etc., whatever is the manufacturer. Oppositely, the manufacturers specific ones are defined only by its manufacturer. As common manufacturer specific parameters, we have calibration settings, material information, linearization curve, etc.

When deforming a standard routine as a calibration, user is conducted step by step by a method. The method is generally defined as guide line to help the user to make common tasks. The **Configuration Tool** identifies each method associated to the parameters and enables the interface to it.

## Terminal Number

It is the parameter, which makes reference to a physical input, which in the turn, is sent internally from the specified transducer output to function block.

It starts at channel one (1) for transducer number one until channel three (3) for transducer number three.

The channel number of the AI block and TOT block is related to the transducer's terminal number. Channel number 1, 2, 3 corresponds bi-univocally to the terminal block with the same number. Therefore, all user has to do is choosing combinations: (1.1), (2.2), (3,3) for (CHANNEL, BLOCK) respectively.

### Functional Diagram of the Current To PROFIBUS PA Transducer Block

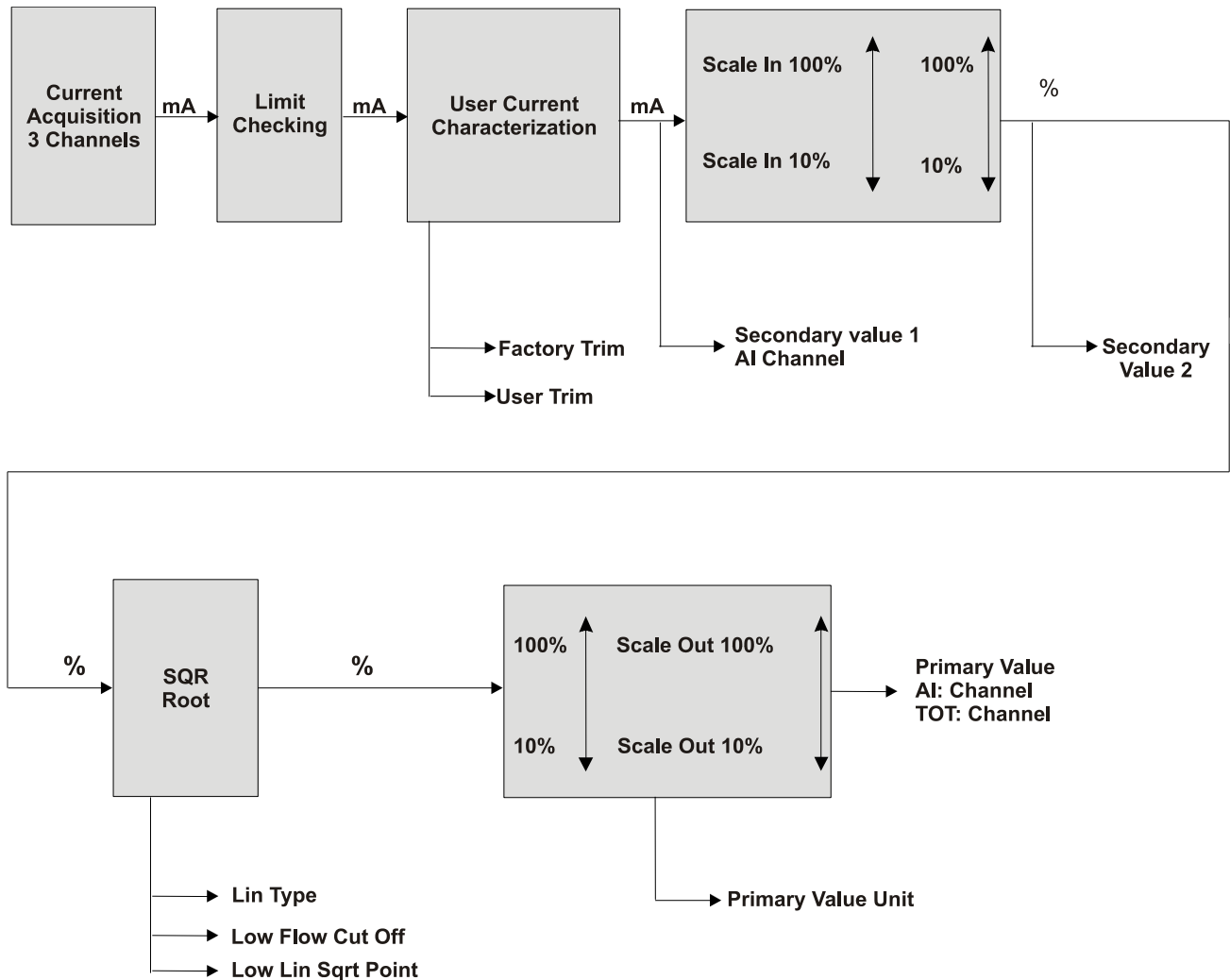

Figure 3.1 - Functional Diagram of the Current To PROFIBUS PA Transducer Block

### Current To PROFIBUS PA Transducer Block General Parameter Description

Parameter	Description
BACKUP_RESTORE	<p>This parameter allows to save and to restore data according to factory and user calibration procedures. It has the following options:</p> <ul style="list-style-type: none"> <li>1, "Factory Cal Restore",</li> <li>2, "Last Cal Restore",</li> <li>3, "Default Data Restore",</li> <li>4, "Shut-Down Data Restore",</li> <li>11, "Factory Cal Backup",</li> <li>12, "Last Cal Backup",</li> <li>14, "Shut-Down Data Backup",</li> </ul>



Parameter	Description
	<b>0</b> , "None".
CAL_MIN_SPAN	This parameter contains the minimum calibration span value allowed. This minimum span information is necessary to ensure that when calibration is done, the two calibrated points (high and low) are not too close together. Unit derives from SENSOR_UNIT.
CAL_POINT_HI	This parameter contains the highest calibrated value. For calibration of the high limit point you give the high measurement value (pressure) to the sensor and transfer this point as HIGH to the transmitter. Unit derives from SENSOR_UNIT.
CAL_POINT_LO	This parameter contains the lowest calibrated value. For calibration of the low limit point you give the low measurement value (pressure) to the sensor and transfer this point as LOW to the transmitter. Unit derives from SENSOR_UNIT.
LIN_TYPE	Linearization Type: <b>0</b> – No Linearization <b>10</b> – Square Root
LOW_FLOW_CUT_OFF	This is the point in percent of flow till that the output of the flow function is set to zero. It is used for suppressing low flow values.
FLOW_LIN_SQRT_POINT	This is the point of the flow function where the curve changes from linear to square root function. The input has to be done in percent of flow.
MAINT_DATE	The date of last maintenance.
EEPROM_FLAG	This parameter is used to indicate EEPROM saving process.
FACTORY_GAIN_REFERENCE	Factory calibration reference value.
MAIN_BOARD_SN	This is the main board serial number.
MAX_SENSOR_VALUE	Holds the maximum process SENSOR_VALUE. A write access to this parameter resets to the momentous value. The unit is defined in SENSOR_UNIT.
MIN_SENSOR_VALUE	Holds the minimum process SENSOR_VALUE. A write access to this parameter resets to the momentous value. The unit is defined in SENSOR_UNIT.
ORDERING_CODE	Indicates information about the sensor and control from production factory.
PRIMARY_VALUE	This parameter contains the measured value and status available to the Function Block. The unit of PRIMARY_VALUE is the PRIMARY_VALUE_UNIT.
PRIMARY_VALUE_TYPE	This parameter contains the application of the device. <b>&gt; 128</b> : manufacturer specific
PRIMARY_VALUE_UNIT	This parameter contains the engineering units index code for the primary value. In this case the unit code is mA (1211).
SECONDARY_VALUE_1	This parameter contains the current value and status available to the Function Block.
SECONDARY_VALUE_1_UNIT	This parameter contains the current units of the SECONDARY_VALUE_1. In this case the unit code is mA (1211).
SECONDARY_VALUE_2	This parameter contains the measured value after input scaling and status available to the Function Block. The related unit is the SECONDARY_VALUE_UNIT_2. In this case the unit code is % (1342).
SECONDARY_VALUE_2_UNIT	This parameter contains the units of the SECONDARY_VALUE_2 defined by the manufacturer. In the this case the unit code mA (1211).
SCALE_IN	This is the input conversion of the current into PRIMARY_VALUE using the high and low scale. The related unit is the PRIMARY_VALUE_UNIT.
SCALE_OUT	This is the output conversion value using the high and low scale. The related unit is the PRIMARY_VALUE_UNIT.
SENSOR_HI_LIM	This parameter contains the sensor upper limit value. Unit derives from SENSOR_UNIT.
SENSOR_LO_LIM	This parameter contains the sensor lower limit value. Unit derives from SENSOR_UNIT.
SENSOR_UNIT	This parameter contains the engineering units index code for the calibration values. In this case the unit code is mA (1211).
SENSOR_SN	The serial number of sensor.
SENSOR_VALUE	This parameter contains the raw sensor value. The uncalibrated measurement value from the sensor. Unit derives from SENSOR_UNIT.
TERMINAL_NUMBER	The terminal number, which references a channel value, which is sent via internal, manufacturer-specific from AI function block to the specified transducer. It starts at one (1) for transducer

Parameter	Description
	number one until three (3) for transducer number three.
TRIMMED_VALUE	This parameter contains the sensor value after the TRIM processing. Unit derives from SENSOR_UNIT.
XD_ERROR	Indicates the condition of calibration process according to: {16, "Default value set"}, {22, "Applied process out of range"}, {26, "Invalid configuration for request"}, {27, "Excess correction"}, {28, "Calibration failed"}

Table 3.1 - Parameter Description

### Transducer Block Parameter Attributes

Relative Index	Parameter Mnemonic	Object Type	Data Type	Store	Size	Access	Parameter usage/ Type of transport	Default value	Down-load Order	Mandatory / Optional (Class)	View
... Standard Parameter											1
Additional Parameter for Transducer Block											
8	SENSOR_VALUE	Simple	Float	D	4	r	C/a	0	-	M (B)	
9	SENSOR_HI_LIM	Simple	Float	N	4	r	C/a	0	-	M (B)	
10	SENSOR_LO_LIM	Simple	Float	N	4	r	C/a	0	-	M (B)	
11	CAL_POINT_HI	Simple	Float	N	4	r,w	C/a	20.0	-	M (B)	
12	CAL_POINT_LO	Simple	Float	N	4	r,w	C/a	4.0	-	M (B)	
13	CAL_MIN_SPAN	Simple	Float	N	4	r	C/a	0	-	M (B)	
14	MAINT_DATE	Simple	Octet String	S	16	w,w	C/a			O(B)	
15	SENSOR_UNIT	Simple	Unsigned 16	N	2	r,w	C/a	1211	-	M (B)	
16	SENSOR_SN	Simple	Unsigned 32	N	4	r,w	C/a		-	M (B)	
17	TRIMMED_VALUE	Record	DS-33	D	5	r	C/a	0.0	-	M (B)	
18	PRIMARY_VALUE	Record	DS-33	D	5	r	C/a	0.0	-	M (B)	1
19	PRIMARY_VALUE_UNIT	Simple	Unsigned 16	N	2	r,w	C/a	-	-	M (B)	
20	PRIMARY_VALUE_TYPE	Simple	Unsigned 16	N	2	r,w	C/a	255	-	M (B)	
21	SECONDARY_VALUE_1	Record	DS-33	D	5	r	C/a	0.0	-	O (B)	
22	SECONDARY_VALUE_1_UNIT	Simple	Unsigned 16	N	2	r,w	C/a	mA	-	O (B)	
23	SECONDARY_VALUE_2	Record	DS-33	D	5	r	C/a	0	-	O (B)	
24	SECONDARY_VALUE_2_UNIT	Simple	Unsigned 16	N	2	r,w	C/a	%	-	O (B)	
25	SCALE_IN	Array	Float	S	8	r,w	C/a	20.0 4.0	-	O(B)	
26	SCALE_OUT	Array	Float	S	8	r,w	C/a	20.0 4.0	-	O(B)	
27	MAX_SENSOR_VALUE	Simple	Float	N	4	r,w	C/a	0.0	-	O (B)	

Relative Index	Parameter Mnemonic	Object Type	Data Type	Store	Size	Access	Parameter usage/ Type of transport	Default value	Download Order	Mandatory / Optional (Class)	View
28	MIN_SENSOR_VALUE	Simple	Float	N	4	r,w	C/a	0.0	-	O (B)	
29	TERMINAL_NUMBER	Simple	Unsigned 8	S	1	r,w	C/a	0	-	O (B)	
30	LIN_TYPE	Simple	Unsigned 8	S	1	r,w	C/a	0	-	O (B)	
31	LOW_FLOW_CUT_OF F	Simple	Float	S	4	r,w	C/a	0	-	O (B)	
32	FLOW_LIN_SQRT_POI NT	Simple	Float	S	4	r,w	C/a	0		O (B)	
33-40	RESERVED										
41	BACKUP_RESTORE	Simple	Unsigned 8	S	1	r,w	C/a	0	-	O (B)	
42	XD_ERROR	Simple	Unsigned 8	D	1	r	C/a	0x10	-	O (B)	
43	MAIN_BOARD_SN	Simple	Unsigned 32	S	4	r,w	C/a	0	-	O (B)	
44	EEPROM_FLAG	Simple	Unsigned 8	D	1	r	C/a	FALSE	-	O (B)	
45	FACTORY_GAIN_REF ERENCE	Simple	Float	S	4	r,w	C/a	0	-	O (B)	
46	ORDERING_CODE	Array	Unsigned 8	S	50	r,w	C/a	-	-	O (B)	

Table 3.2 - Parameter Attribute

See FUNCTION BLOCKS PROFIBUS PA manual for more parameters information, by visiting our web page on the Internet: <http://www.smar.com>.

## IF303 - CYCLIC CONFIGURATION

The PROFIBUS DP and PROFIBUS PA protocols have mechanisms against communication failures between the slave device and the network master. For example, during initialization, these mechanisms are used to check these possible errors. After powering up the field device (slave), it can cyclically exchange information with the class 1 master, if the parameterization for the slave is correct. This information is obtained using the GSD files (supplied by the device manufacturer, it contains their descriptions). Through the commands below, the master executes all initialization process with the PROFIBUS PA device:

- Get\_Cfg: uploads the slave configuration on the master and checks network configuration;
- Set\_Prm: writes to the slave parameters and executes the parameterization network;
- Set\_Cfg: configures the slaves according to its outputs and inputs;
- Get\_Cfg: another command, where the master checks the slave configuration.

All these services are based on the information obtained from slave gsd files. The GSD file from IF303 shows details such as, hardware and software revision, device bus timing and information about cyclic data exchange.

IF303 has 6 function blocks: 3 AIs (Analog Input) and 3 TOTs (Totalizer). It also has the empty module for applications where not all function blocks are necessary. The following cyclic order of the blocks should be respected: AI\_1, AI\_2, AI\_3 and TOT\_1, TOT\_2, TOT\_3. Suppose, only the AIs blocks are necessary, then configure this way: AI\_1, AI\_2, AI\_3, EMPTY\_MODULE, EMPTY\_MODULE, EMPTY\_MODULE.

Nevertheless, if you want to work only 1 AI and 1 TOT, configure them this way: AI\_1, EMPTY\_MODULE, EMPTY\_MODULE and TOT\_1, EMPTY\_MODULE, EMPTY\_MODULE.

Most PROFIBUS configuration tools use two directories where the different manufacturers' GSD's and BITMAPS files are stored. The GSD's and BITMAPS for Smar devices can be obtained through the website: (<https://www.smar.com>), select "Download" option in the product specific page.

The following example shows the necessary steps to integrate the IF303 on a PROFIBUS system.

These steps are valid for the entire 303 line of Smar devices:

- Copy the IF303 gsd file to the research directory of the PROFIBUS configuration tool, usually called GSD;
- Copy the IF303 bitmap file to the research directory of the PROFIBUS configuration tool usually called BMP;
- After choosing the master, define the communication rate. Do not forget that the couplers may have the following fixed communication rates 45,45 kbits/s (Siemens) or 93,75 kbits/s (P+F) and variable comm rates up to 12 Mbit/s as instance: SK2 and SK3 from P+F, link IM157 from Siemens and Smar's controllers with embedded couplers (DF95 or DF97);
- Add the IF303 and specify its physical bus address;
- Choose the cyclic configuration via parameterization using the gsd file that depends on the application, as detailed previously. For every AI (Analog Input) block, the IF303 provides the process variable to the master in 5 bytes value, being the first four according to float point data type and the fifth byte is the status that brings the measure quality of this information.

In the TOT (Totalizer) block, the user can choose the totalization value (Total) and the integration is made considering the operation mode (Mode\_Tot). It allows defining of how the totalization will be, with the following options: only positive value of the flow, only negative values of the flow, or both. In this block, the user can reset the totalization and configure the preset value through the Set\_Tot parameter. The reset option is very used in batch processes;

- It allows activating the condition of watchdog, which the device goes to a fail safe condition, when a loss of communication is detected with the master.



Using **ProfibusView**, **AssetView for FDT** from Smar or **Simatic PDM** configuration software from Siemens, for instance, user may configure parameters of the Input Transducer block. See Figure 3.2 - Function and Transducers Blocks.

The device was created as IF303.

Here it is possible to see all instantiated function blocks.

Transducer and Display are treated as special type of Function Blocks, called Transducer Blocks.

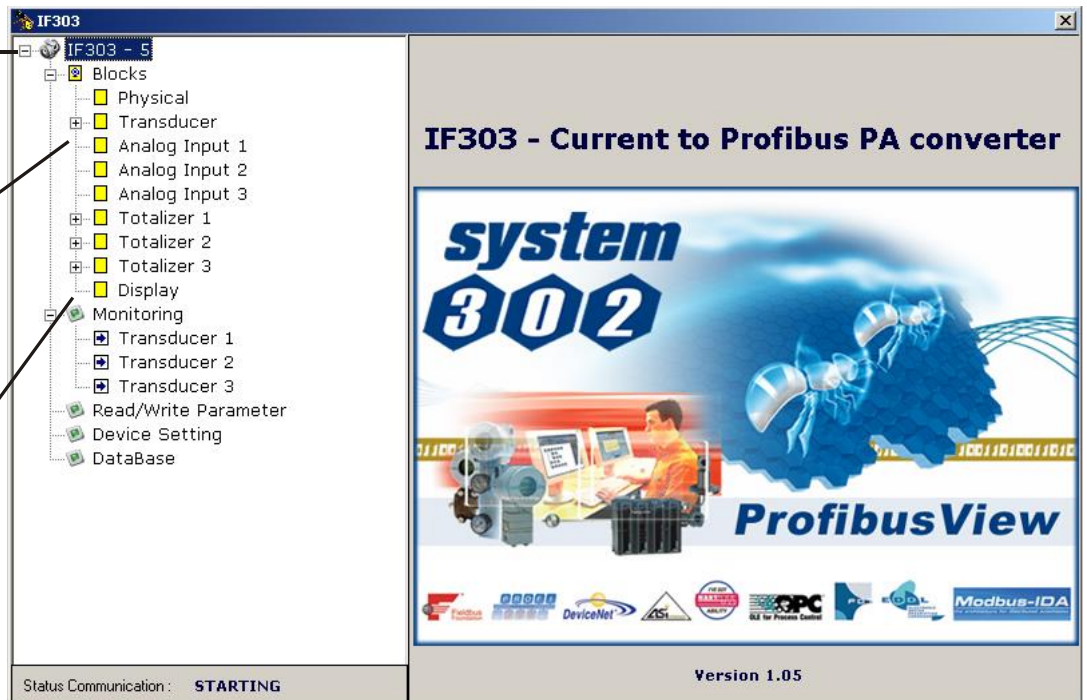

Figure 3.2 – Function and Transducers Blocks – ProfibusView

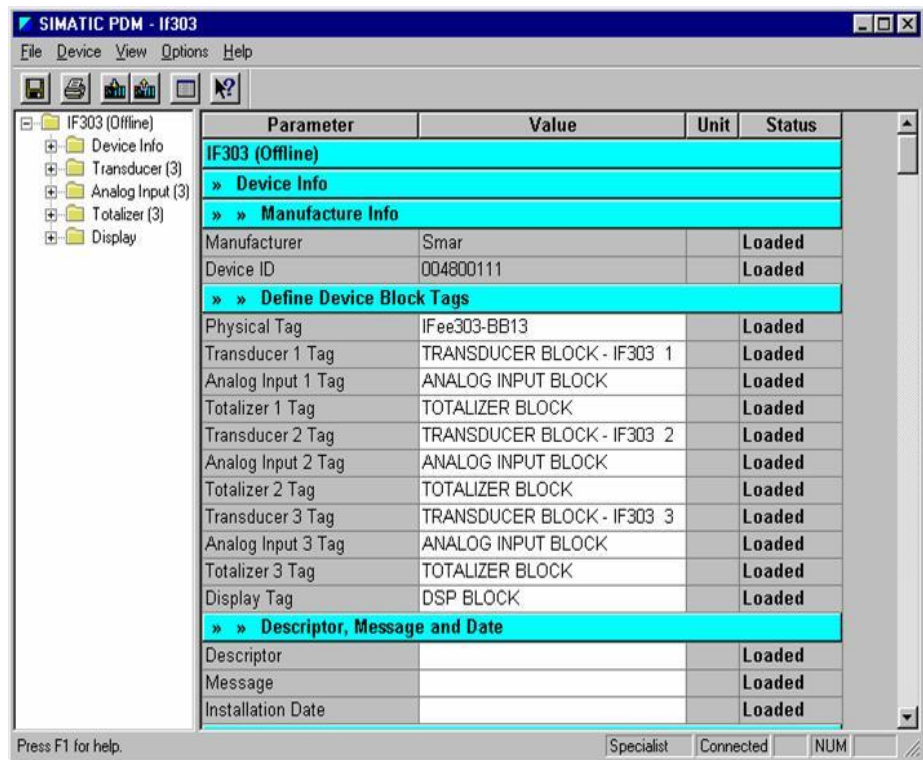

Figure 3.3 – Function and Transducers Blocks – Simatic PDM

To make the configuration of Transducer Block, select on the main menu:

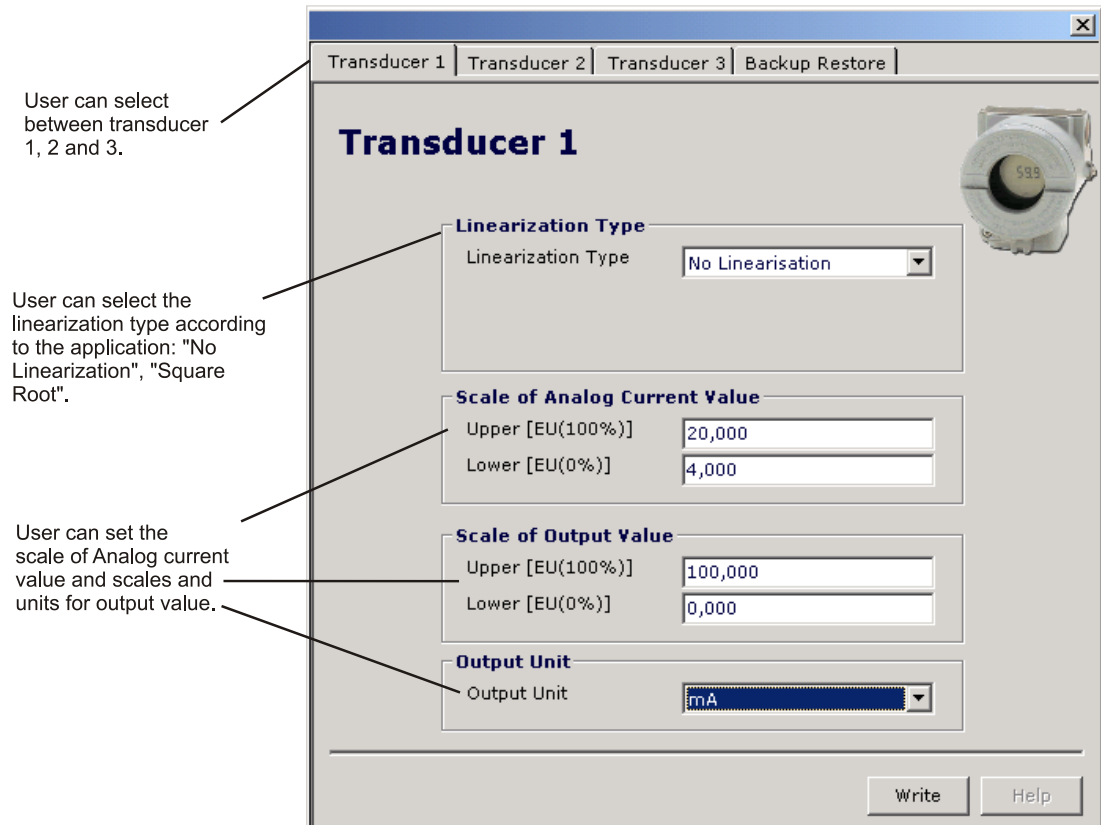
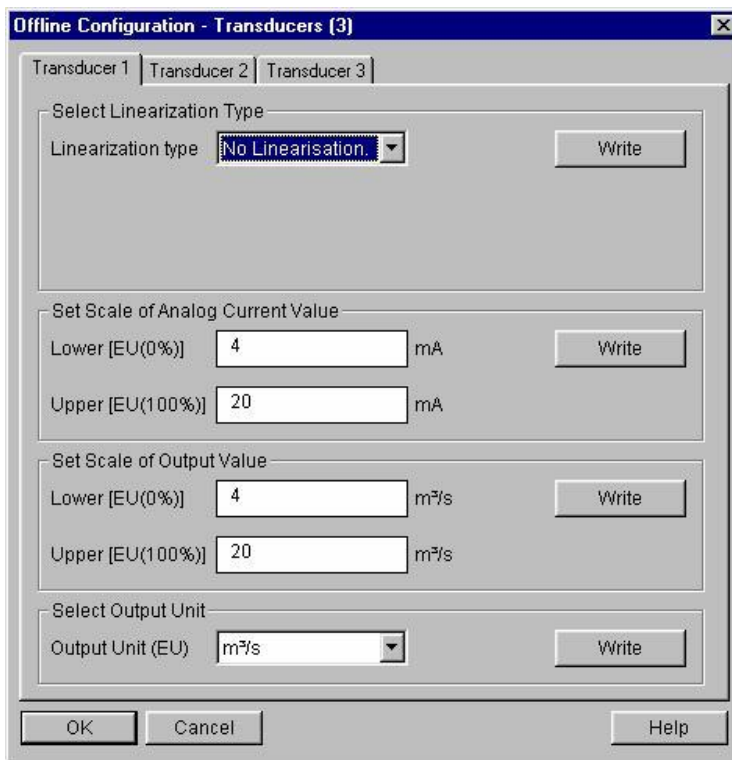

Figure 3.4 - Transducer Block – ProfibusView.



**Figure 3.5 - Transducer Block - Simatic PDM**

When the user chooses "Square Root", he needs to configure more two parameters: "Low Flow Cutoff" and "Flow Lin Sqr Point". For details, please see last figure and the diagram of Transducer Block.

In terms of Square Root, we have the following feature:

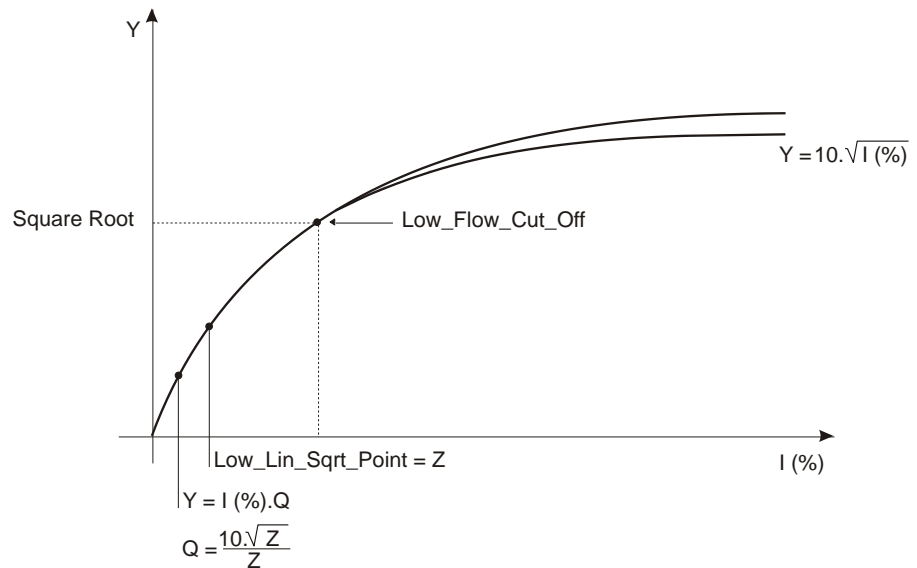

**Figure 3.6 – Square Root Calculation.**

## How to Configure the Analog Input Block

The Analog Input block takes the input data from the Transducer block, selected by channel number, and makes it available to other function blocks at its output. The transducer block provides the input unit of the Analog Input, and when the unit is changed in the transducer, the PV\_SCALE unit is changed too. Optionally, a filter may be applied in the process value signal, whose time constant is PV\_FTIME. Considering a step change to the input, this is the time in seconds to the PV reaches 63,2% of the final value. If the PV\_FTIME value is zero, the filter is disabled. For more details, please, see the Function Blocks Specifications.

To configure the Analog Input Block select on the main menu. Using this window, the user can configure the block mode operation, selects the channel, scales and unit for input and output value and the damping.

User can set the block mode operation.

User can select PV (Primary Value), Sec Value 1 (Secondary Value 1) or Sec Value 2 (Secondary Value 2) for the channel.

Scale of input value. The unit comes from the transducer block.

Scales and unit for the output value.

User can set the PV damping.

**Analog Input 1 Block**

Target: MAN Channel: Disconnected

**Scale of Input Value**

Upper [EU(100%)] 100,000

Lower [EU(0%)] 0,000

Unit psi

**Scale of Output Value**

Upper [EU(100%)] 50,00

Lower [EU(0%)] 0,000

Unit psi

**Damping Value**

Damping 1,000 s

Write Help

Figure 3.7 – Basic Settings for Analog Input Block – ProfibusView.

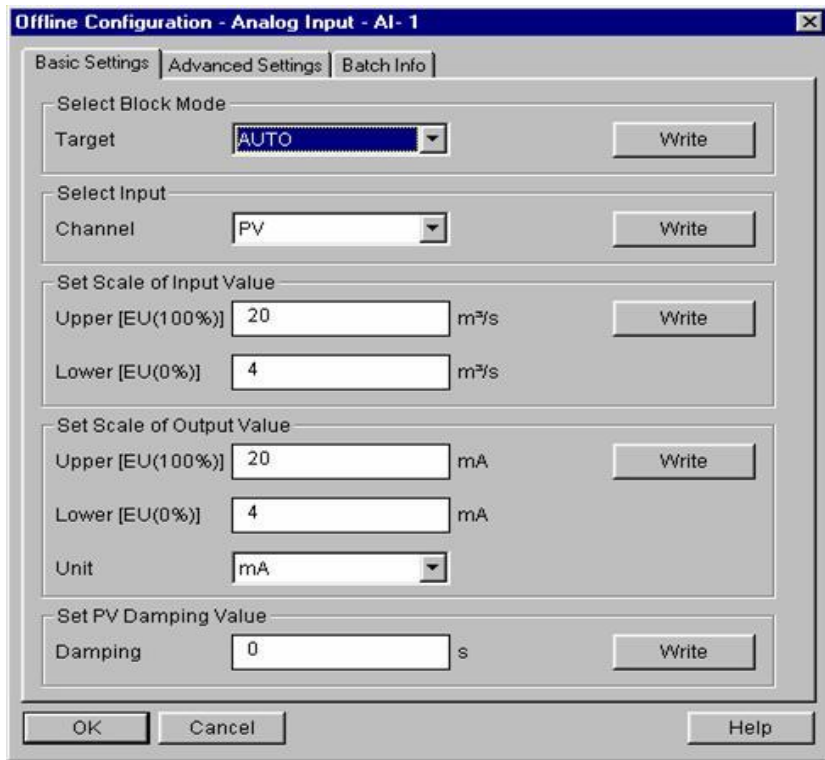

Figure 3.8 – Basic Settings for Analog Input Block - Simatic PDM.

Selecting the page "Advanced Settings", the user can configure the conditions for alarms and warnings, as well the fail safe condition. Please, see the next window:

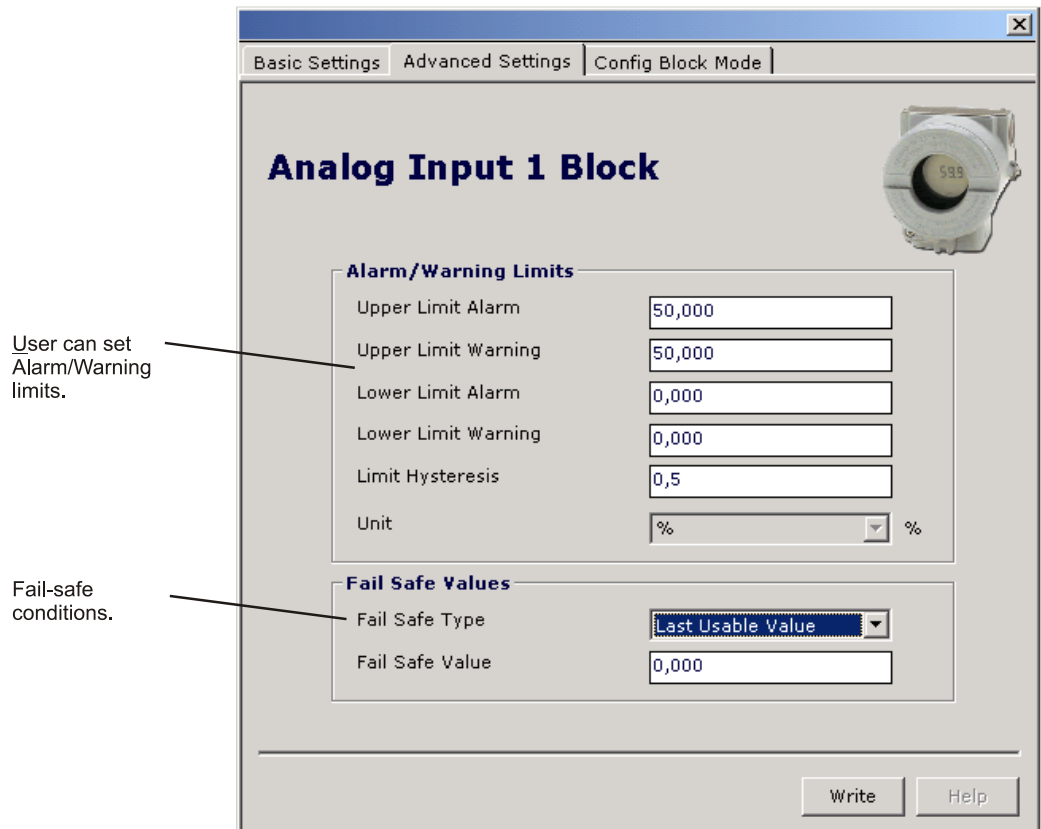

Figure 3.9 - Advanced Settings for Analog Input Block – ProfibusView.



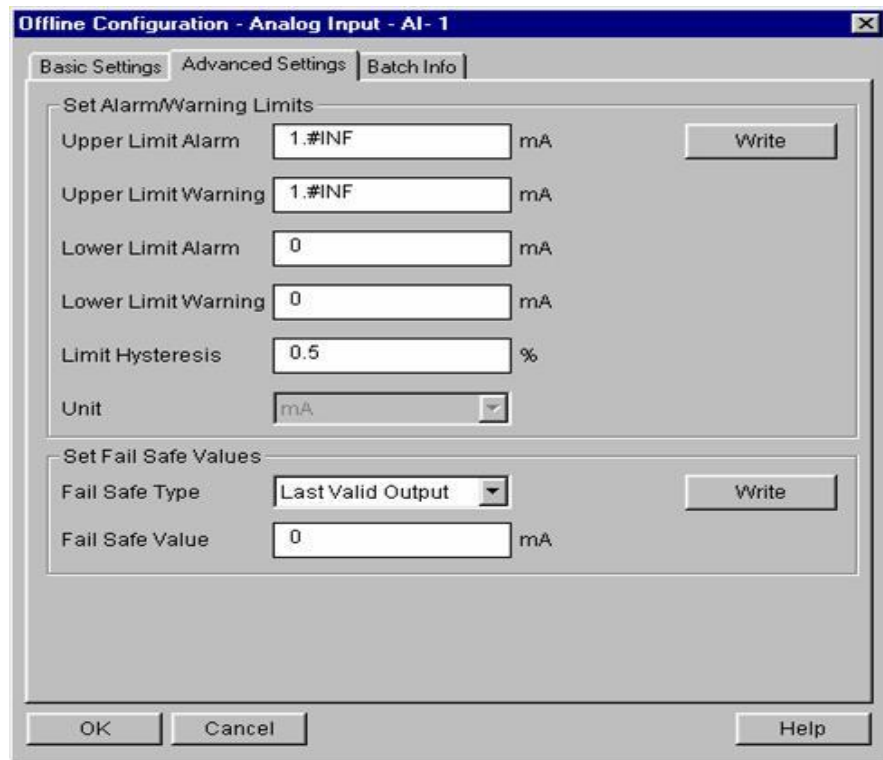

Figure 3.10 - Advanced Settings for Analog Input Block - Simatic PDM.

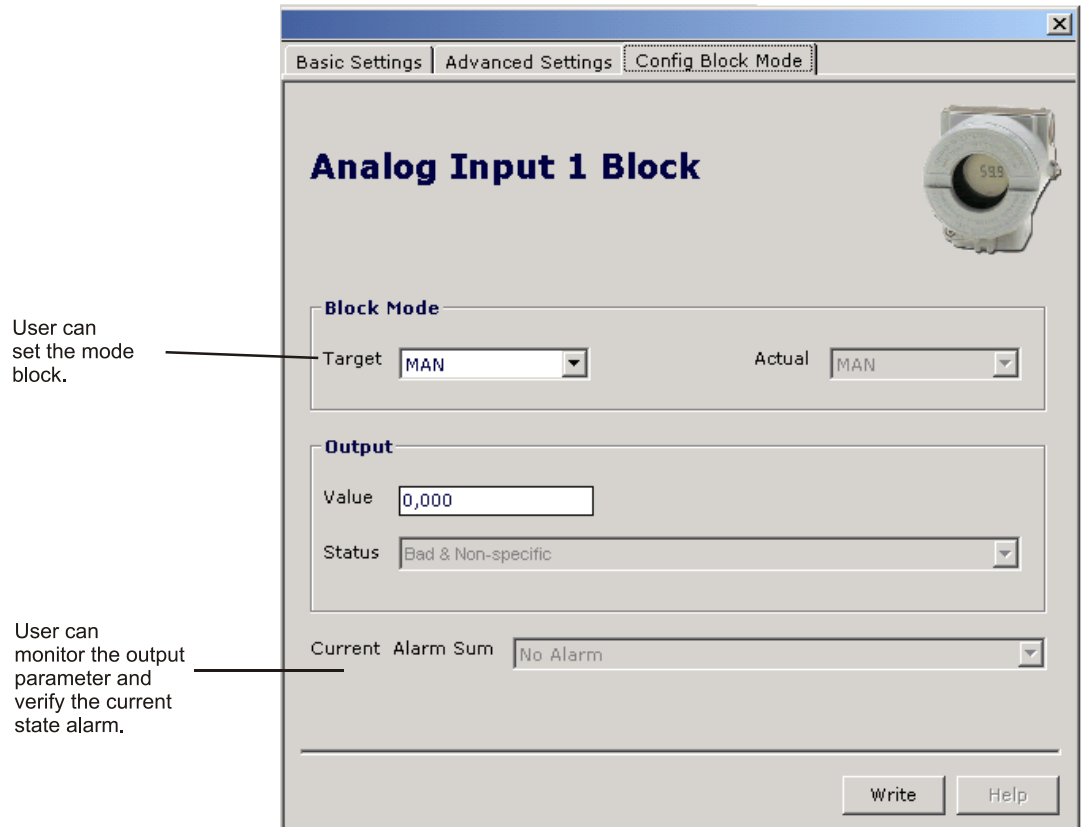

Figure 3.11 - Configuration for Analog Input Block – Profibus View.

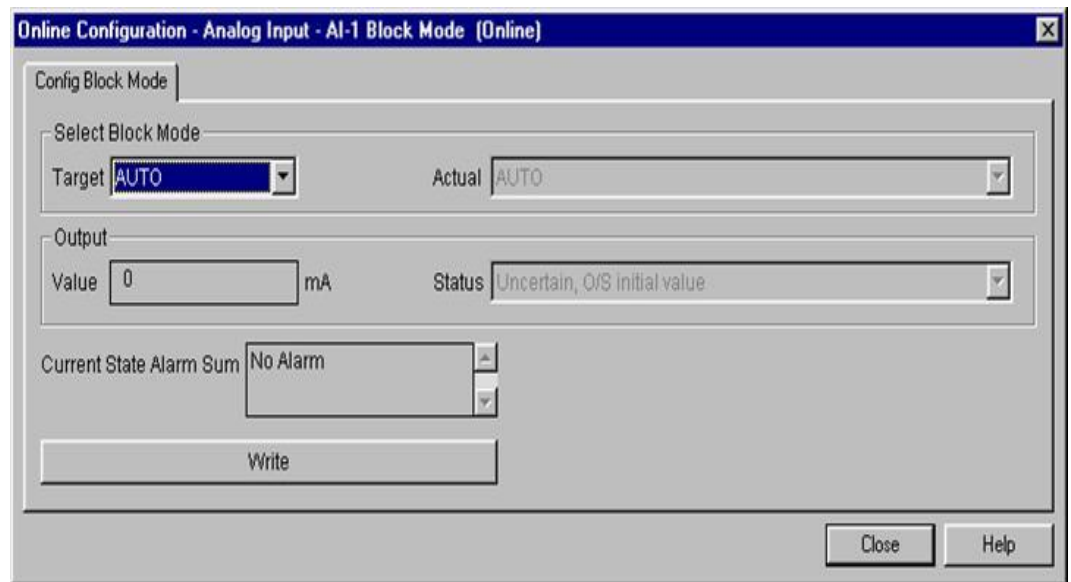

Figure 3.12 - Configuration for Analog Input Block - Simatic PDM.

## How to configure the Totalizer Block

The Totalizer function block obtain the input data from the Transducer block, selected by channel number, and integrates over the time. This block is normally used to totalize flow, giving total mass or volume over a certain time, or totalize power, giving the total energy.

The Totalizer Function Block integrates a variable (e.g flow rate or power) in function of the time to the corresponding quantity (e.g., volume, mass or distance). The rate unit of the Totalizer is providing by the transducer block. Internally, the time units are converted in rate units per second. Each rate, multiplied by the block execution time, gives the mass, volume or energy increment per block execution.

The TOTAL is the totalized quantity. The engineering unit used in the output is the UNIT\_TOT. The unit of the output must be compatible with the unit of the input provided by the transducer by the channel. Then, if the input the rate is mass flow (like Kg/s, g/min, ton/h) the unit of the output must be mass (like kg, g, ton, lb, etc.). For more details, please, see the Function Blocks Specifications.

To configure the Totalizer Block select on the main menu. Using this window, the user can configure the block mode operation, selects the channel, totalizer mode and unit for the total. The user can choose up to 3 Totalizer Blocks:

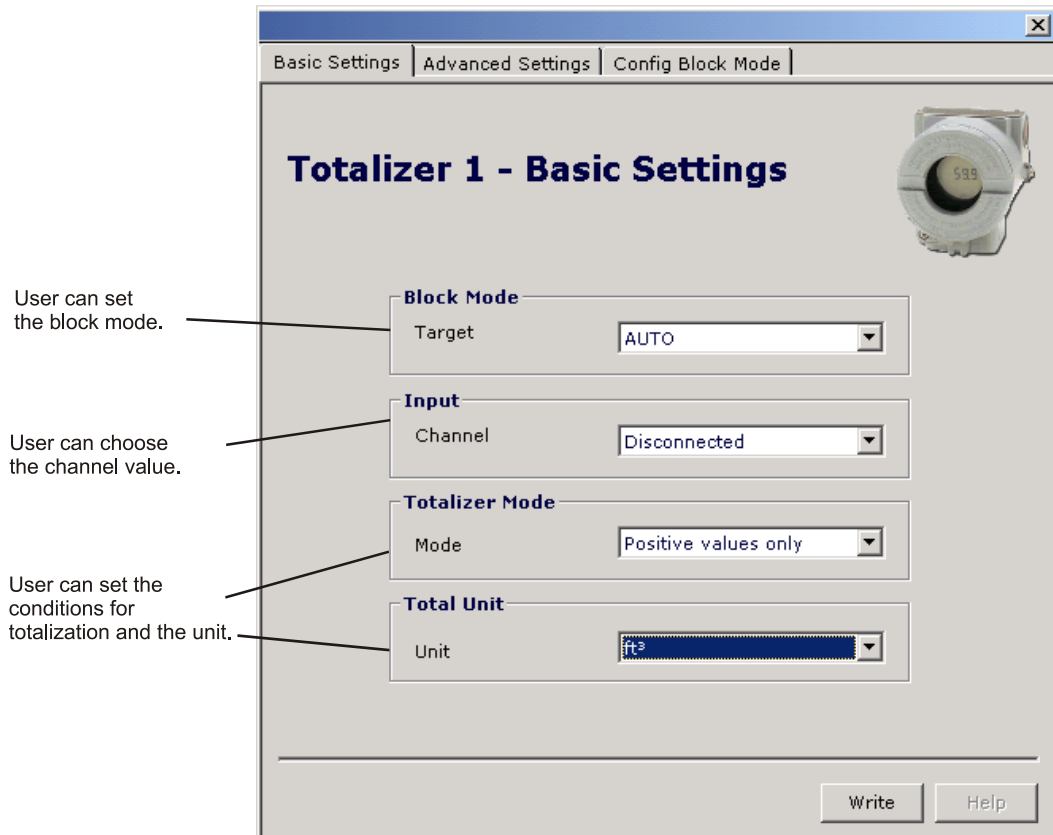

Figure 3.13 - Basic Settings for Totalizer Block – ProfibusView

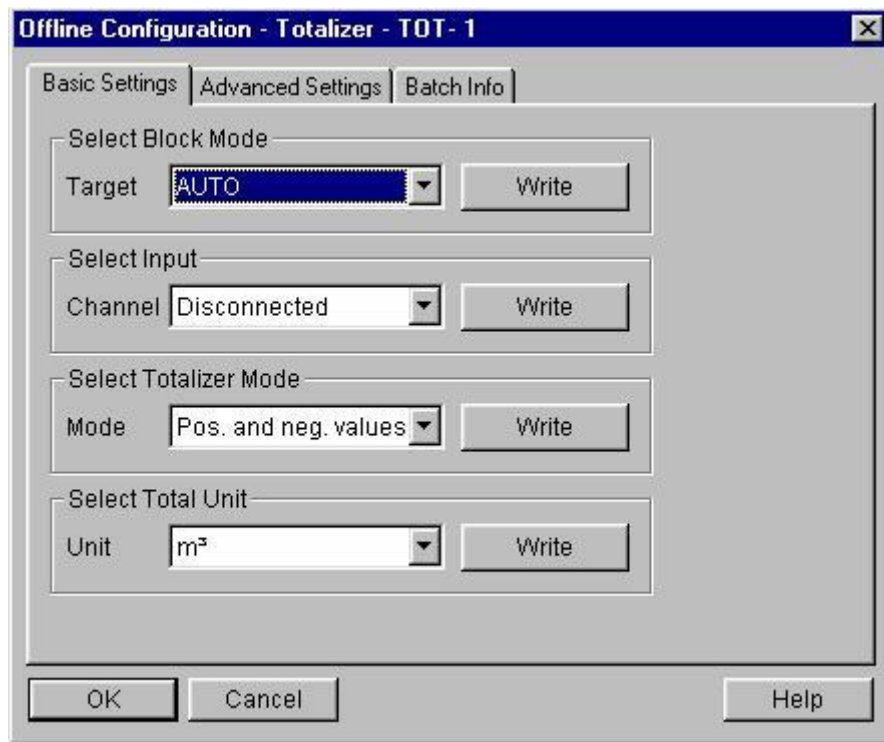

Figure 3.14 - Basic Settings for Totalizer Block - Simatic PDM

Choosing the "Advanced Settings" window, the user can set alarm and warning limits, as well the fail safe condition:

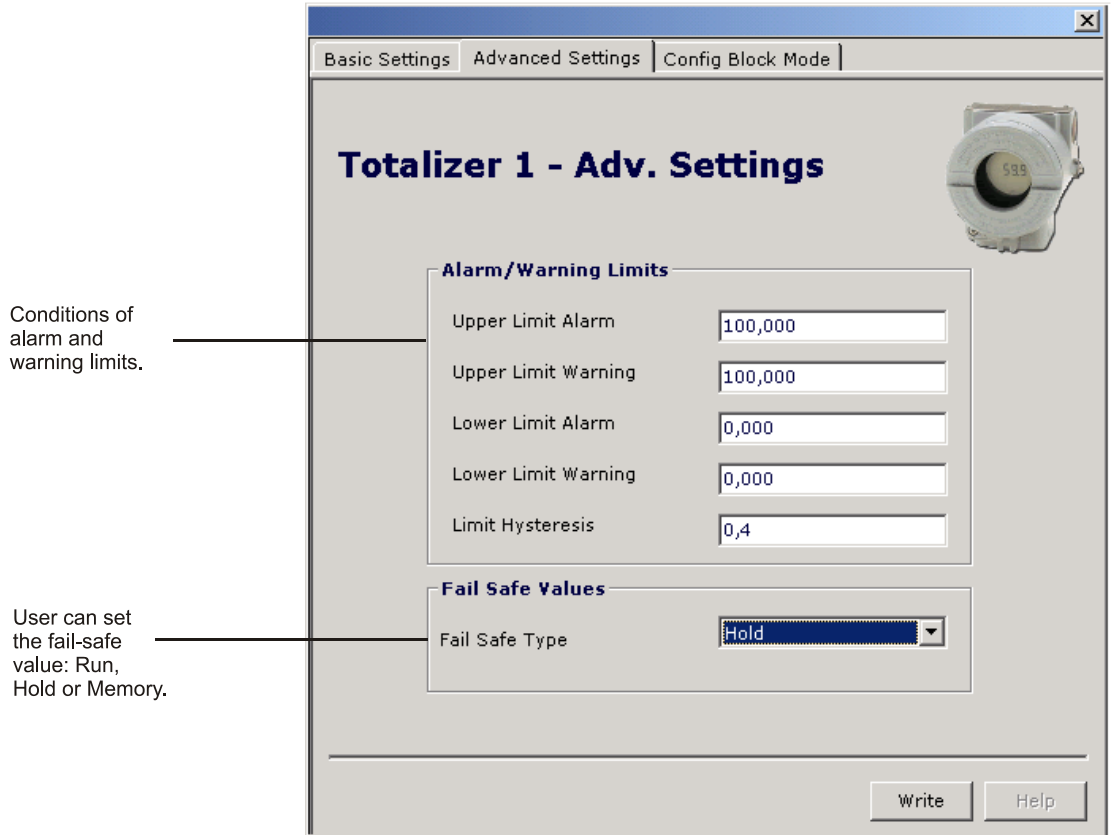

Figure 3.15 - Advanced Settings for Totalizer Block - Profibus View.

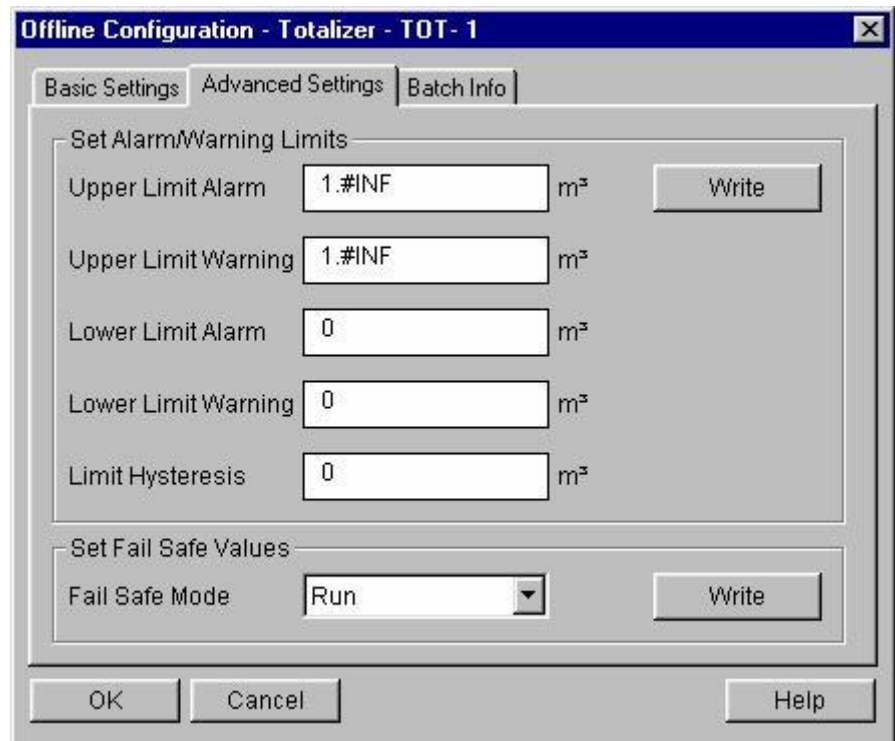

Figure 3.16 - Advanced Settings for Totalizer Block - Simatic PDM

In the screen Config Block Mode the user can adjust the operation of the block.

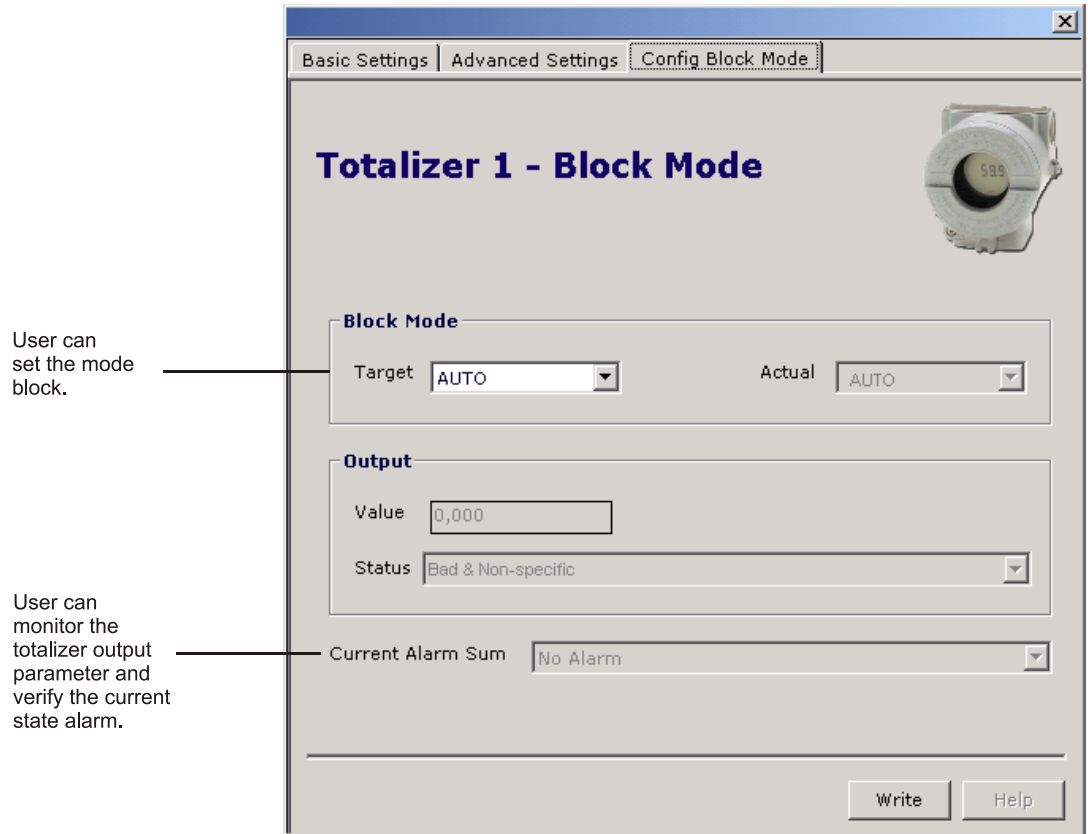

Figure 3.17 - Totalizer Block Configuration - ProfibusView.

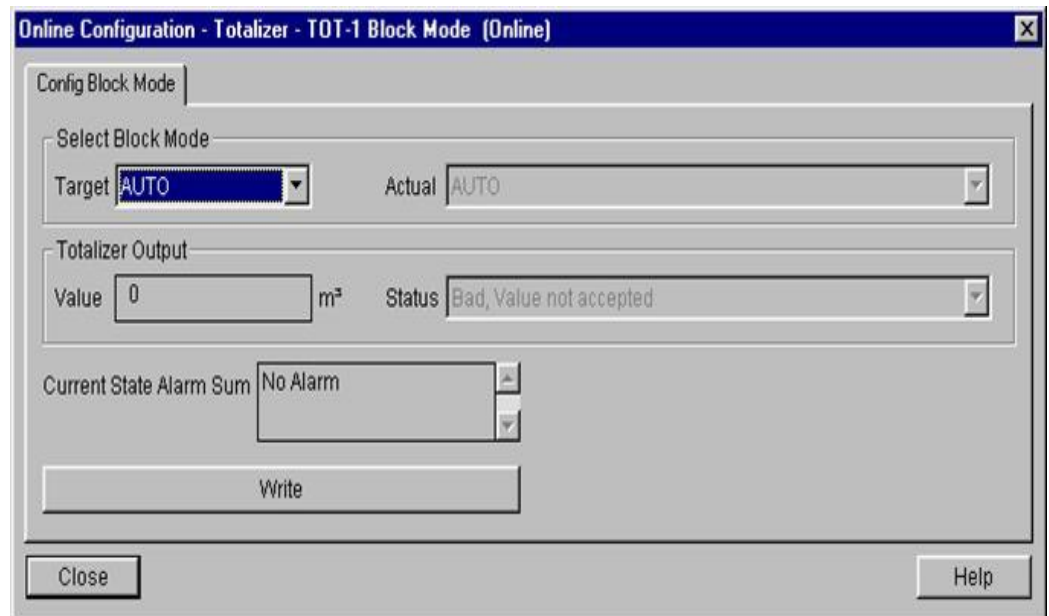

Figure 3.18 - Totalizer Block Configuration - Simatic PDM.

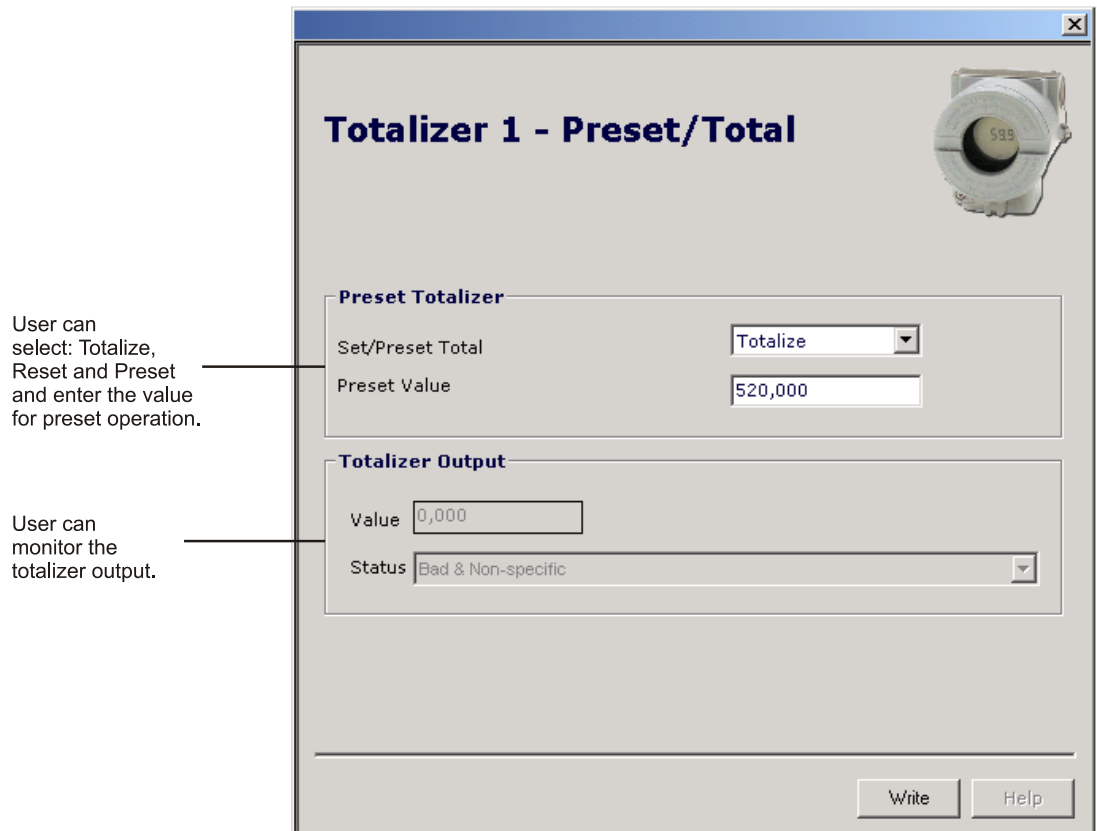

Figure 3.19 - Set/Preset Configuration for Totalizer Block - ProfibusView

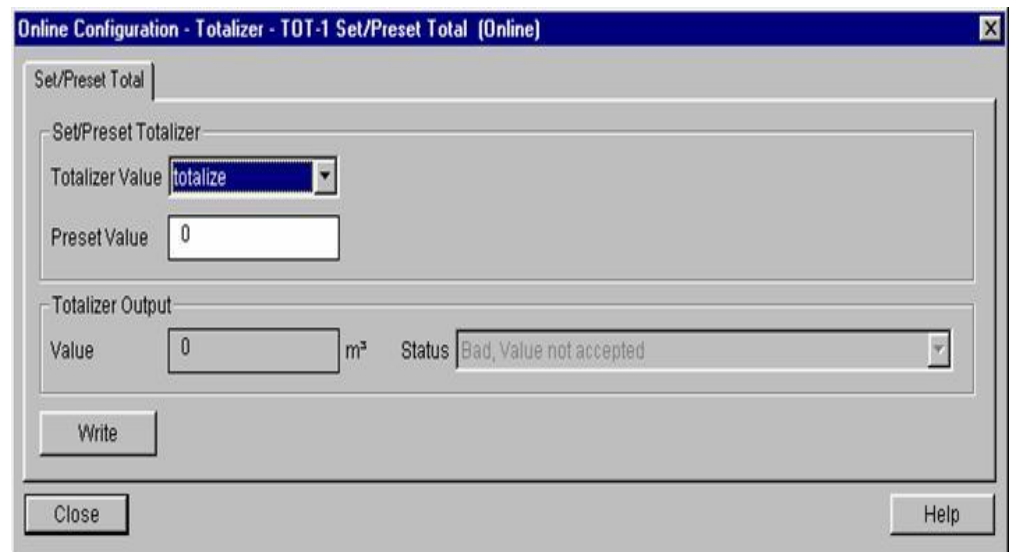

Figure 3.20 - Set/Preset Configuration for Totalizer Block - Simatic PDM

## Current Trim

The IF303 provides the capability of making a TRIM in the input channels, if necessary.

TRIM procedure is necessary if the indication reading of the transducer block output differs from the actual physical output. The reason may be:

- User's current meter differs from the factory standard.
- Converter had its original characterization signal shifted by over-load or by long term drift.

User can check the calibration of the transducer output by measuring the actual current in the input and compare it with the indication of the device (an appropriate meter must be used). If a mismatch is detected, a TRIM can be done.

TRIM can be done in two points:

**Lower TRIM:** Is used to TRIM the lower value of the input range.

**Upper TRIM:** Is used to TRIM the upper value of the input value.

These two points define the linear characteristic of the output. TRIM in one point is independent from the other.

There are at least two ways of doing the TRIM: using local adjustment or using a **Configuration Tool** (see below examples using **ProfibusView**).

When doing the TRIM, make sure you are using an appropriate meter (with the necessary accuracy).

**Via ProfibusView, AssetView for FDT or Simatic PDM**

The channel number of the AI block is related to the transducer's terminal block number. Channel number 1,2,3 corresponds bi-univocally to the terminal block with the same number. Therefore, all the user has to do is to select combinations: (1, 1), (2, 2), (3, 3), for (CHANNEL, TERMINAL NUMBER).

It is possible to calibrate the current inputs of the transmitter by means of parameters CAL\_POINT\_LO and CAL\_POINT\_HI.

Let's take the lower value as an example:

Supply 4 mA or the lower value to the terminal block and wait until the readout of parameter PRIMARY\_VALUE stabilizes.

Write 4.00 or the lower value in parameter CAL\_POINT\_LO. For each value written a calibration is performed at the desired point.

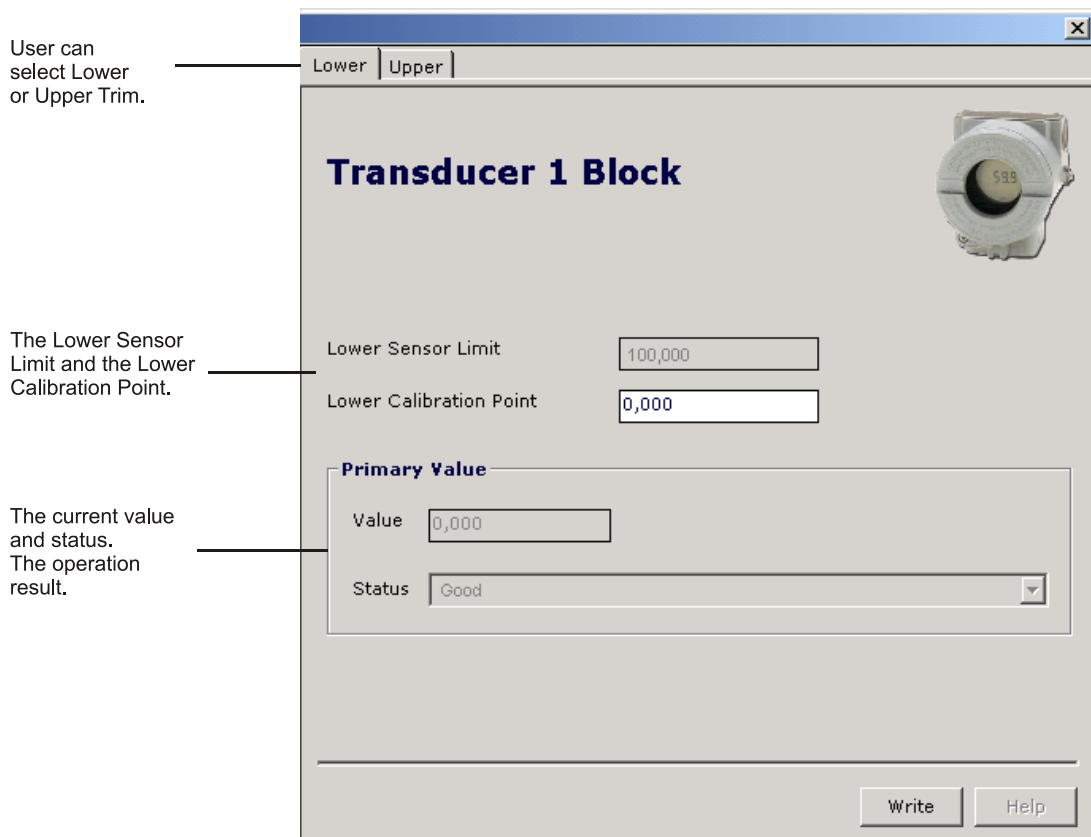

Figure 3.21 - Lower Current Calibration - ProfibusView.

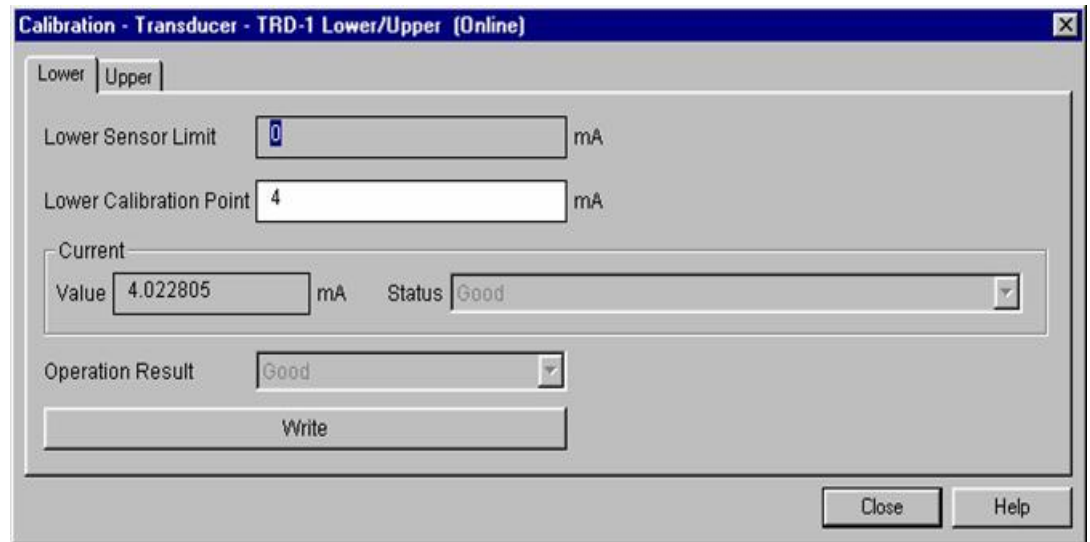

Figure 3.22 – Lower Current Calibration - Simatic PDM.

Let's take the upper value as an example:  
 Supply 20 mA or the upper value to the terminal block and wait until the readout of parameter PRIMARY\_VALUE stabilizes.  
 Write 20.00 or the upper value in parameter CAL\_POINT\_HI. For each value written a calibration is performed at the desired point.

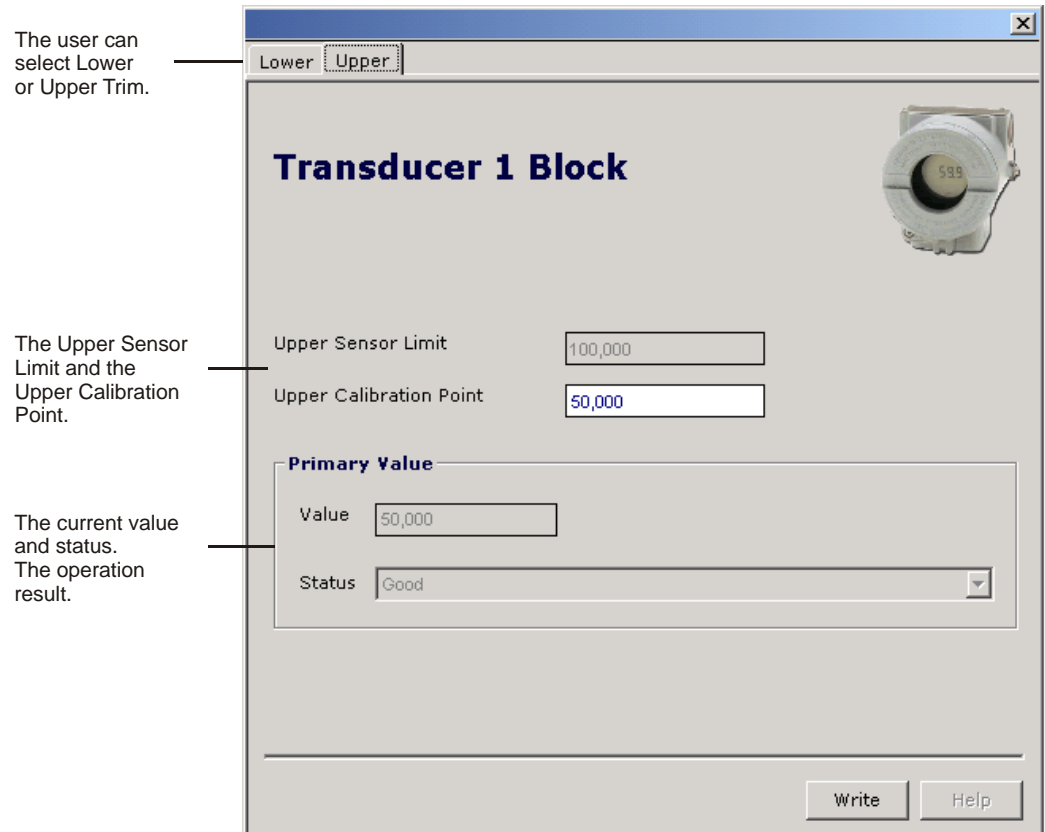

Figure 3.23 - Upper Current Calibration - ProfibusView.



**Figure 3.24 - Upper Current Calibration - Simatic PDM.**

#### WARNING

It is recommended, for every new calibration, to saving the existent TRIM data by means of parameter BACKUP\_RESTORE, using option "Last Cal Backup".

## Via Local Adjustment

The **IF303** has 3 input transducers and it is provided by SMAR with default settings. The factory setting establishes only the transducers #1 as default for local adjustment. In order to configure the others via local adjustment, user shall configure them in the display transducer via Configuration Tool, according specific instructions for this transducer block.

In order to enter the local adjustment mode, place the magnetic tool in orifice "Z" until flag "MD" lights up in the display. Remove the magnetic tool from "Z" and place it in orifice "S" until the message "LOC ADJ" is displayed. The message will be displayed during approximately 5 seconds after the user has removed the magnetic tool from "S". By placing the magnetic tool the user will be able to access the local adjustment tree in the monitoring mode.

Browse to parameter P\_VAL (PRIMARY\_VALUE).

Supply 4.0mA or the lower value to the terminal block and wait until the read of the parameter stabilizes in the display.

Browse to parameter "LOWER". After that, in order to start calibration, the user will act on the parameter "LOWER" by placing the magnetic tool in "S" down to 4.0 mA.

Let's take the upper value:

Supply 20.0mA or the upper value to the terminal block and wait until the readout of parameter P\_VAL stabilizes, and then actuate parameter UPPER up to 20.0.

TRIM mode exits via local adjustment automatically when the magnetic tool is not used during approximately 16 seconds.

#### NOTE

Keep in mind that even when parameters LOWER or UPPER present the desired value, they must be actuated so that calibration is performed.

#### Limit Conditions for Calibration:

For every writing operation in the transducer blocks there is a code indication for the operation associated with the writing method. These codes appear in parameter XD\_ERROR every time a calibration is performed. Code 16, for example, indicates a successfully performed operation.

#### Lower:

0.0mA < NEW\_LOWER < 9.0mA  
 Otherwise, XD\_ERROR = 22

**Upper:**  
 15.0 mA < NEW\_UPPER < 22.0mA  
 Otherwise, XD\_ERROR = 22.

NOTE	
<b>Codes for XD_ERROR:</b>	
<b>16:</b>	Default Value Set
<b>22:</b>	Out of range
<b>26:</b>	Invalid Calibration request
<b>27:</b>	Excessive Correction

## Transducer Display – Configuration

Using the **ProfibusView, AssetView for FDT, Simatic PDM or any other configuration tool** is possible to configure the Display Transducer block. As described above it is a transducer due the interfacing of its block with the LCD hardware.

Transducer Display is treated as a normal block by **any configuration tool**. It means, this block has some parameters and those ones can be configured according to customer's needs.

Customer can choose up to six parameters to be shown at LCD display, they can be parameters just for monitoring purpose or for acting locally in the field devices by using a magnetic tool. The seventh parameter is used to access the physical device address. The user can change this address according to his application. To configure the Display Block select on the main menu:

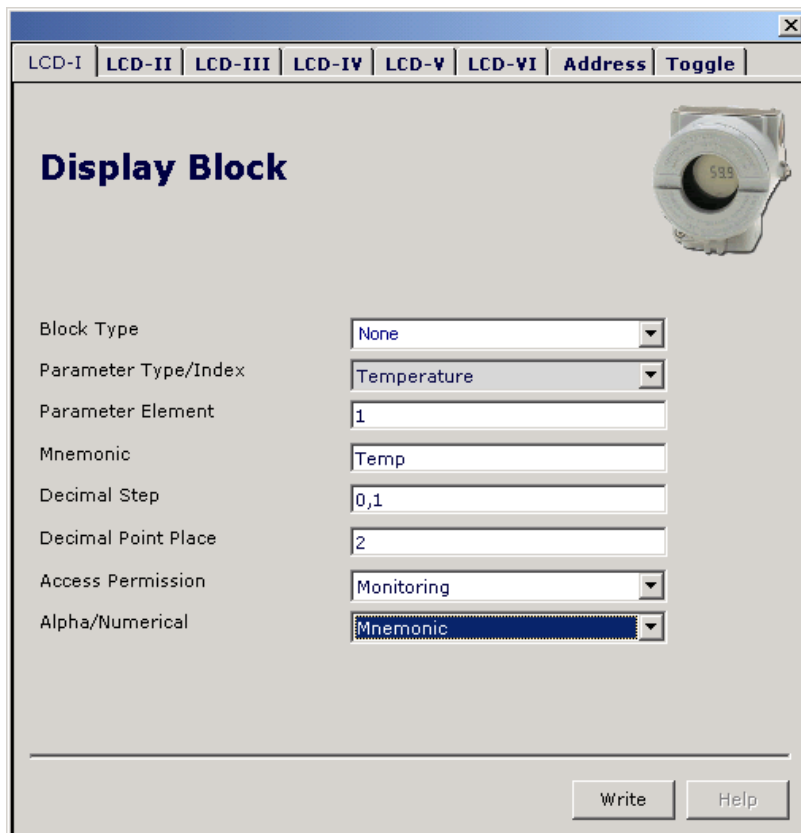

Figure 3.25 - Display Block - ProfibusView.

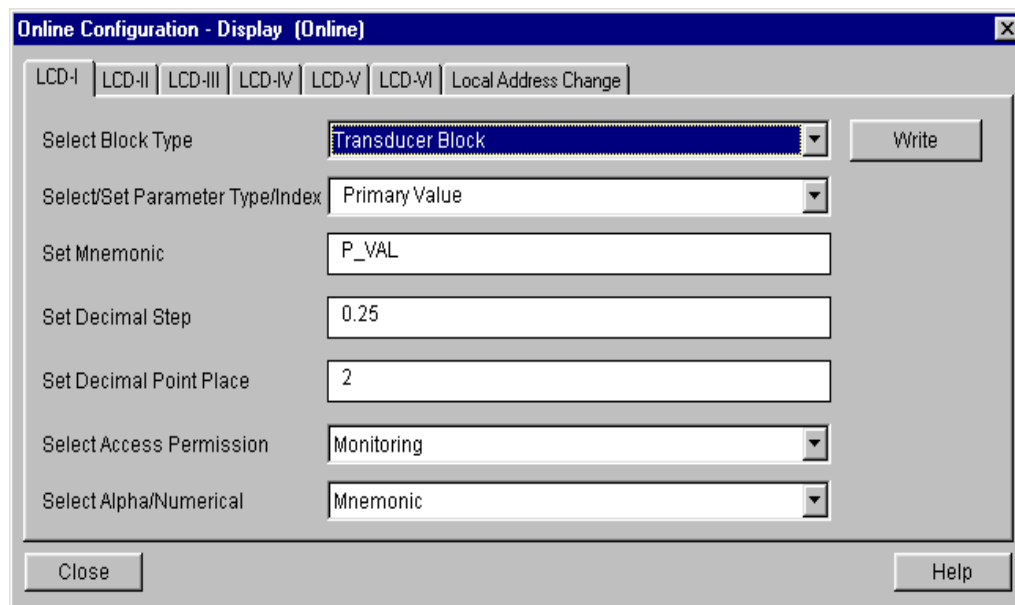

Figure 3.26 - Display Block - Simatic PDM.

## Display Transducer Block

Local adjustment is completely configured by **configuration tool**. It means, user can select the best options to fit his application. From factory, it is configured with the options to set the Upper and Lower TRIM, for monitoring the input transducer output and check the Tag. The converter is much better configured by **configuration tool**, but the local functionality of the LCD permits an easy and fast action on certain parameters, since it does not rely on communication and network wiring connections. Among the possibilities by Local Adjustment, the following options can be emphasized: Mode block, Outputs monitoring, Tag visualization and Tuning Parameters setting.

The interface is described in details on the "General Installation, Operation and Maintenance Procedures Manual". Please take a detailed look at this manual in the chapter related to "Programming Using Local Adjustment". The same handling methodology used for this transducer display can also be used for the 303 Series field devices from Smar. So, since the user has learned once, he is capable to handle all kind of field devices from SMAR.

All function block and transducers defined according PROFIBUS PA have a description of their features written by the Device Description Language.

**This feature allows third-parties configuration tools, enabled by Device Description Service technology, interpreting these features and make them accessible to user Function Blocks and Transducers of 303 Series have been defined rigorously according the PROFIBUS PA specifications in order to be interoperable to other parties.**

In order to enable local adjustment using the magnetic tool, it is necessary to previous setup of parameters related with this operation via System Configuration.

There are six groups of parameters, which one may be pre-configured by the user in order to enable, a possible configuration by means of the local adjustment. Use "NONE" option in the "Select Block Type" parameter to hide unnecessary items to be displayed. Doing this, device will not take the parameters related (indexed) to its Block as a valid parameter.

## Definition of Parameters and Values

### Select Block Type

This is the type of the block where the parameter is located. The user can choose: Transducer Block, Analog Input Block, Totalizer Block, Physical Block or None.

### Select/Set Parameter Type/Index

This is the index related to the parameter to be actuated or viewed (0, 1, 2...). For each block there are some pre-defined indexes. Refer to the Function Blocks Manual to know available indexes to be used.

**Set Mnemonic**

Mnemonic for the parameter identification (it is allowed a maximum of 16 characters into the alphanumeric field of the display). Choose the mnemonic, preferably with no more than 5 characters in order to avoid the display rotation.

**Set Decimal Step**

It is the increment and decrement in decimal units when the parameter is Float or Float Status value; integer, when the parameter is in whole units.

**Set Decimal Point Place.**

This is the number of digits after the decimal point (0 to 3 decimal digits).

**Set Access Permission**

Allows user to read, in the case of the “Monitoring” option, and to write when "action" option is selected, then the display will show the increment and decrement arrows.

**Set Alpha Numerical**

These parameters include two options: value and mnemonic. In option value, it is possible to display both data in the alphanumeric and in the numeric fields; this way, in case of a data higher than 10000, it will be shown in the alphanumeric field. It is useful when we are showing Totalization at the LCD interface.

Selecting mnemonic, display may show the data in the numeric field and the mnemonic in the alphanumeric field.

**NOTE**

For devices where the software version is higher or equal to 1.10, please see the configuration of local adjustment using the local adjustment, in the Installation, operation and maintenance procedures manual.

In case you wish to visualize a certain tag, opt for the index relative equal to "tag". To configure other parameters just select "LCD-II" up to "LCD-VI" windows:

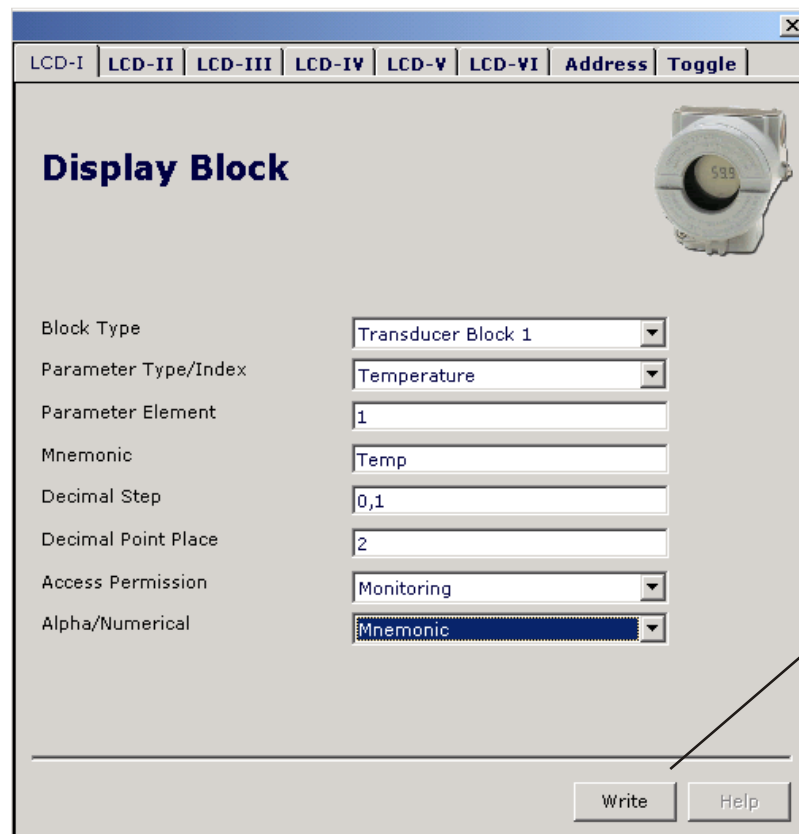

The option "Write" should be selected in order to execute the upgrade of local adjustment programming tree. After its step all the selected parameters will be shown on the LCD display.

**Figure 3.27 - Parameters for Local Adjustment Configuration - ProfibusView.**

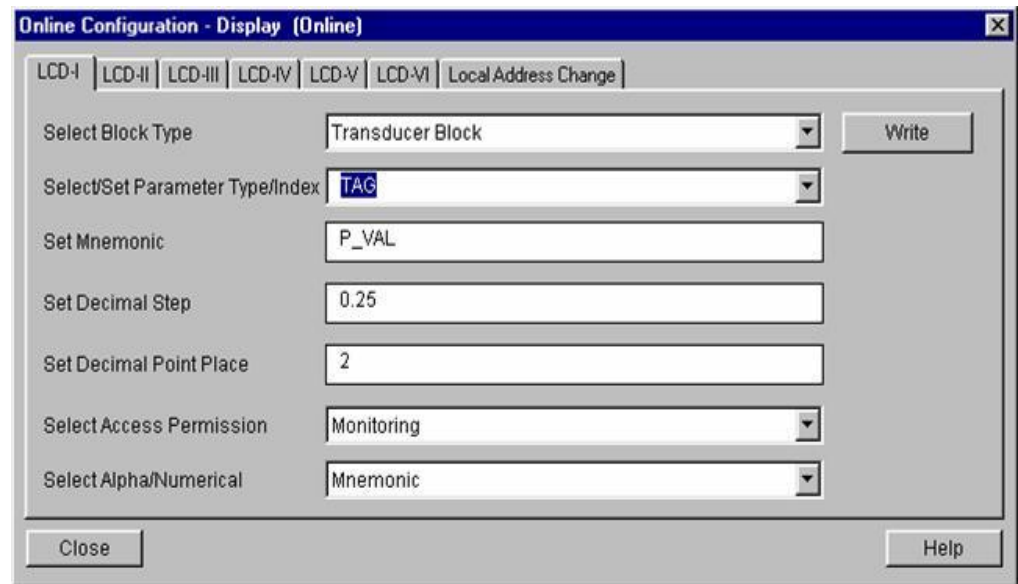

**Figure 3.28 - Parameters for Local Adjustment Configuration - Simatic PDM.**

The window "Local Address Change" allows the user "enable/disable" the access to changing the physical device address.

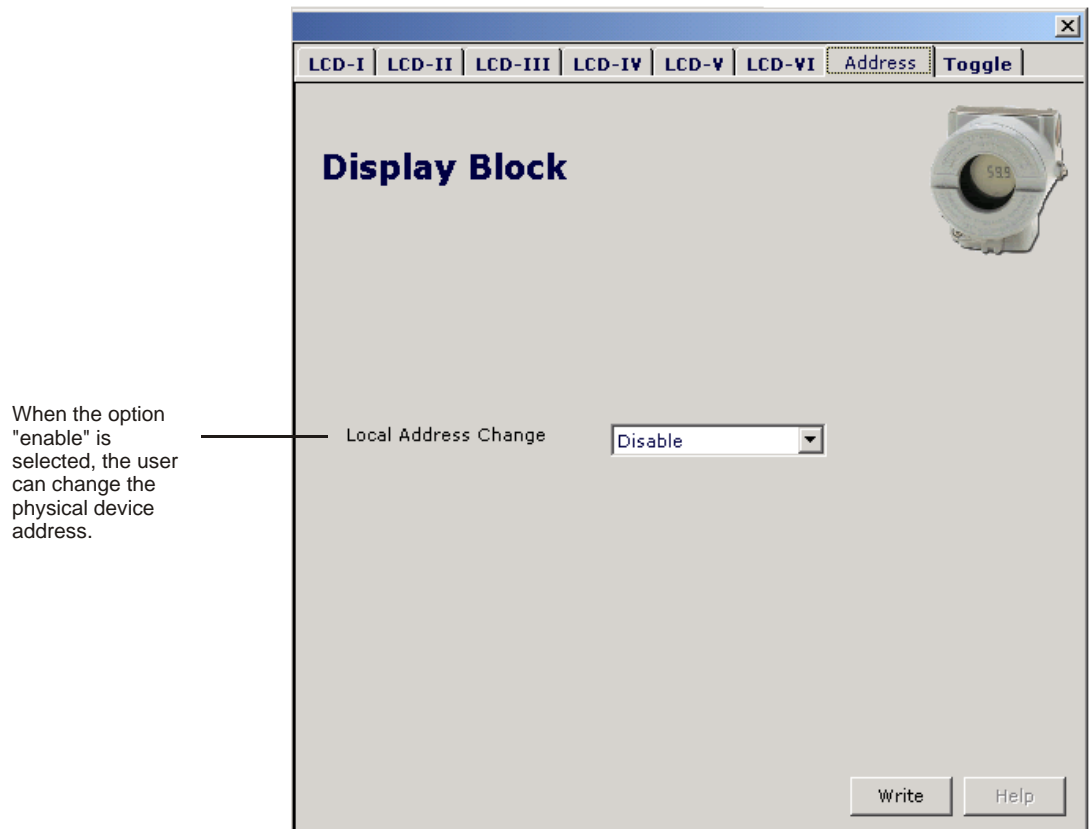

**Figure 3.29 - Parameters for Address Configuration - ProfibusView**

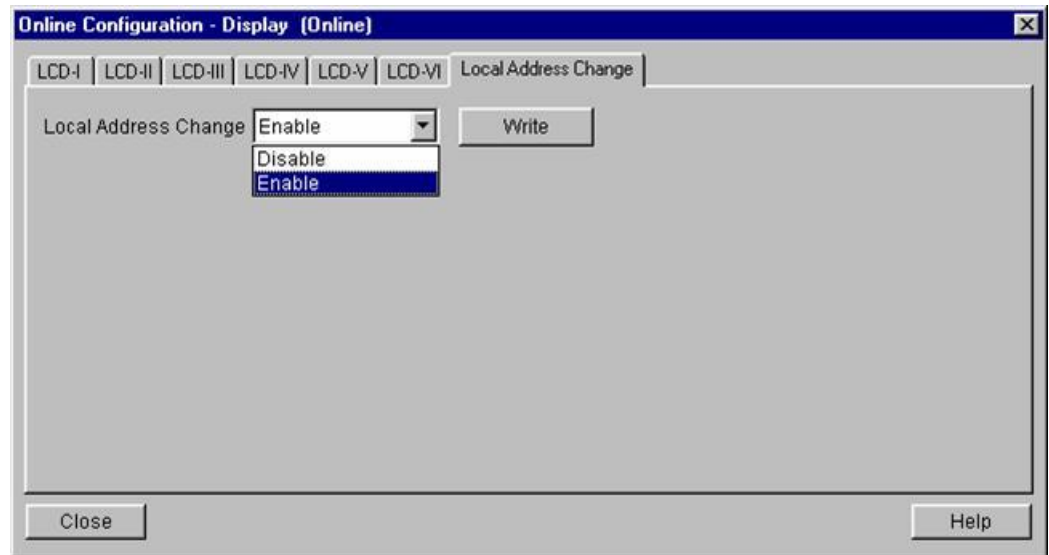

Figure 3.30 - Parameters for Address Configuration - Simatic PDM.

When user is in the local adjustment, he can rotate parameters using the magnet screwdriver. Normally; primary value (P\_VAL) is the standard parameter to be shown. In case of setting another parameter to be displayed, user shall change "Access Permission" to "Monitoring". Thus the last parameter set to "Monitoring" will be displayed after removing the magnet tool.

Always on the LCD interface will be shown two parameters at the same time, switching between the configured parameter at the LCD-II and the last monitoring parameter. If user does not want to show two parameters at the same time, it is only needed to set "none" when configure the LCD-II:

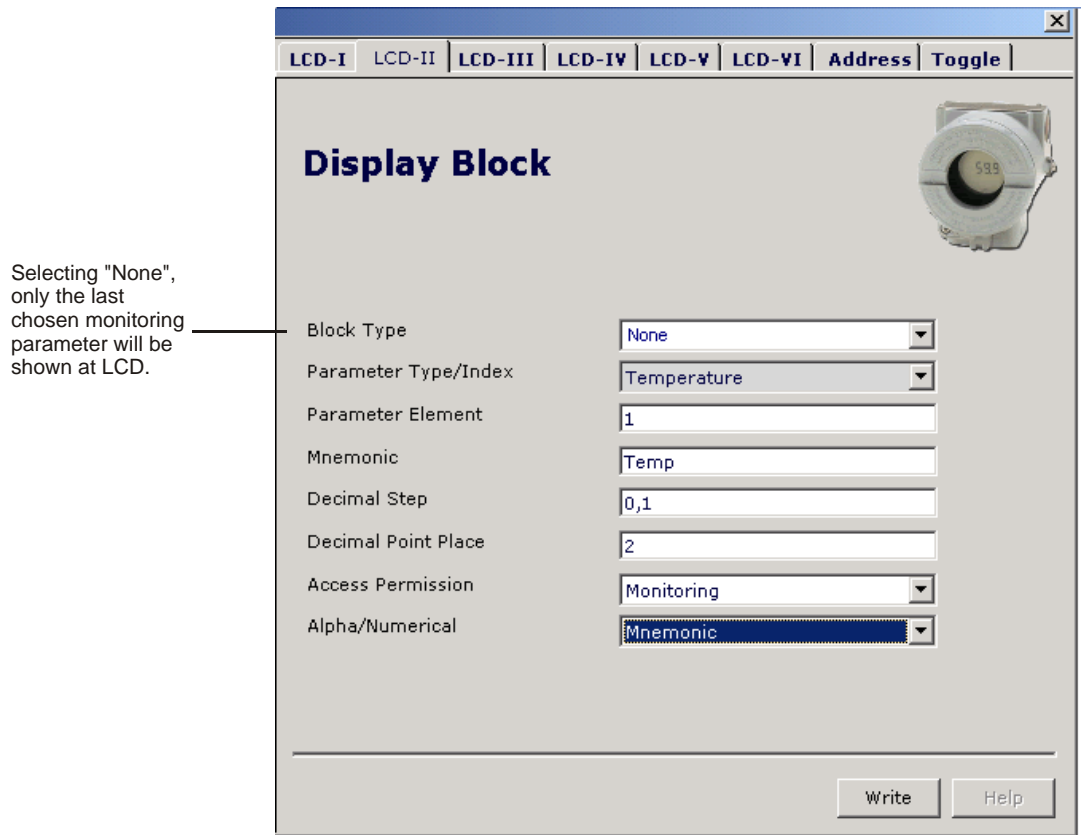
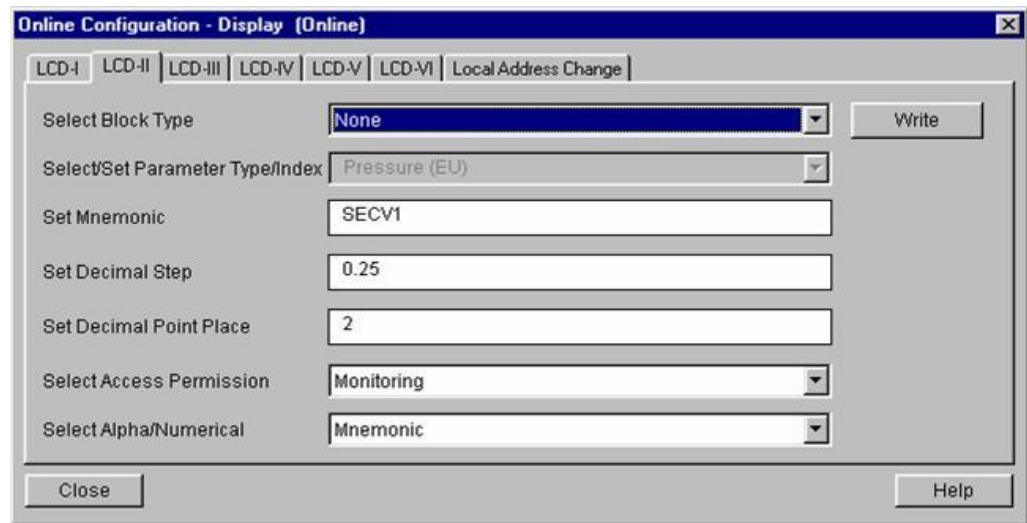
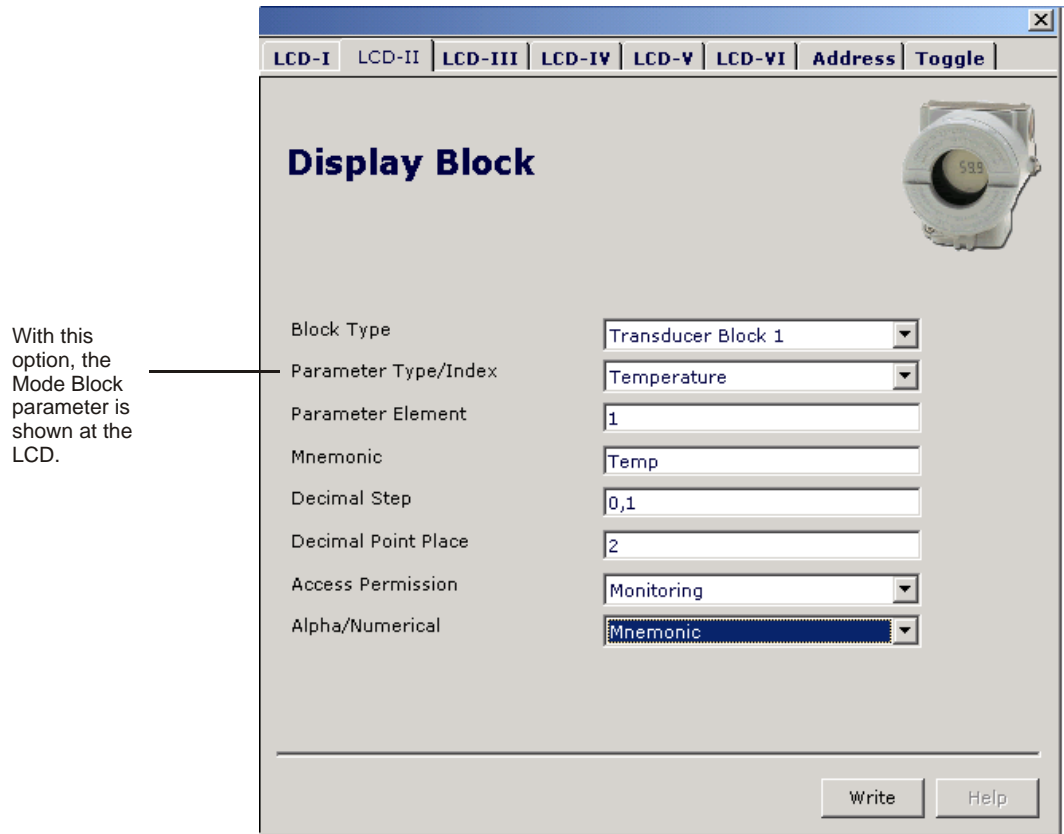

Figure 3.31 - Parameters for LCD-II Configuration - ProfibusView.



**Figure 3.32 - Parameters for LCD-II Configuration - Simatic PDM.**

The user can select the "Mode Block" parameter at the LCD. In this case is necessary to select the index equal to "Mode Block":



**Figure 3.33 - Parameters for Local Adjustment Configuration - ProfibusView.**

The screenshot shows a software window titled "Online Configuration - Display [Online]". At the top, there are tabs for "LCD-I", "LCD-II", "LCD-III", "LCD-IV", "LCD-V", "LCD-VI", and "Local Address Change". The "Local Address Change" tab is selected. Below the tabs, there are several configuration fields:

- Select Block Type:** A dropdown menu showing "Analog Input".
- Select/Set Parameter Type/Index:** A dropdown menu showing "Mode Block".
- Set Mnemonic:** A text input field containing "MODE".
- Set Decimal Step:** A text input field containing "0.25".
- Set Decimal Point Place:** A text input field containing "2".
- Select Access Permission:** A dropdown menu showing "Monitoring".
- Select Alpha/Numerical:** A dropdown menu showing "Mnemonic".

At the bottom of the window, there are three buttons: "Close" on the left, "Write" on the right (next to the "Select Block Type" dropdown), and "Help" on the far right.

Figure 3.34 - Parameters for Local Adjustment Configuration - Simatic PDM.

## Programming Using Local Adjustment

The local adjustment is completely configured by **configuration tool**. It means, the user can select the best options to fit his application. From factory, it is configured with the options to set the Upper and Lower TRIM, for monitoring the input transducer output and check the Tag.

Normally, the converter is much better configured by **configuration tool**, but the local functionality of the LCD permits an easy and fast action on certain parameters, since it does not rely on communication and network wiring connections. Among the possibilities by Local Adjustment, the following options can be emphasized: Mode block, Outputs monitoring, Tag visualization and Tuning Parameters setting.

The interface between the user is also described very detailed on the "General Installation, Operation and Maintenance Procedures Manual". Please take a detailed look at this manual in the chapter related to "Programming Using Local Adjustment". It is significantly the resources on this transducer display, also all the 303 Series field devices from **SMAR** has the same methodology to handle with it. So, since the user has learned once, he is capable to handle all kind of field devices from **SMAR**. This Local adjustment configuration is a suggestion only. The user may choose his preferred configuration via configuration tool, simply configuring the display block).

The converter has two holes for magnetic switches activated by the magnetic tool located under the identification plate. These magnetic switches are activated by one magnetic tool (see figure 3.35).

This magnetic tool enables adjustment of the most important parameters of the blocks. It also enables pre-configuration of the communication.

The jumper W1 on top of the main circuit board must be in place for this function to be enabled and the converter must be fitted with the digital display for access to the local adjustment. Without the display the local adjustment is not possible.



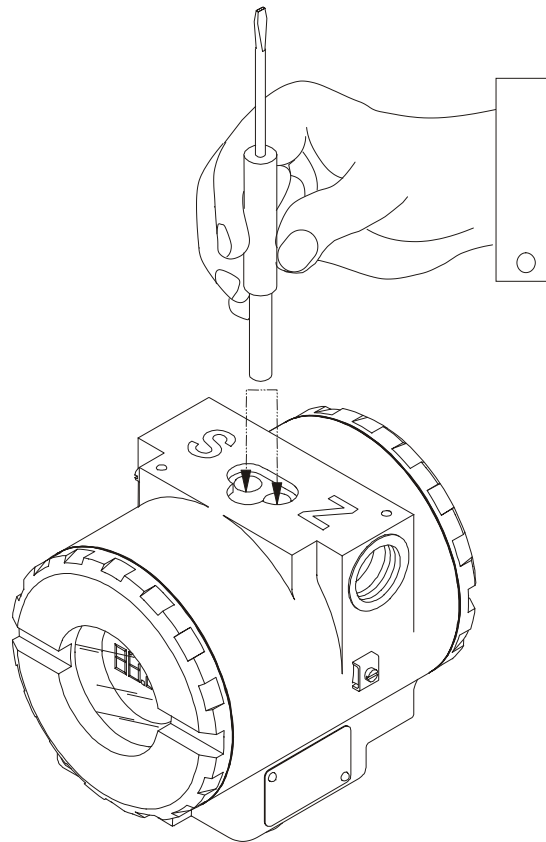

**Fig. 3.35 - Local Adjustment Holes**

Table 3.4 shows the actions on the **Z** and **S** holes on the FY303 when Local Adjustment is enabled.

HOLE	ACTION
<b>Z</b>	Initializes and rotates through the available functions.
<b>S</b>	Selects the function shown in the display.

**Table 3.4 - Purpose of the holes on the Housing**

# Quick Guide – Local adjustment Tree

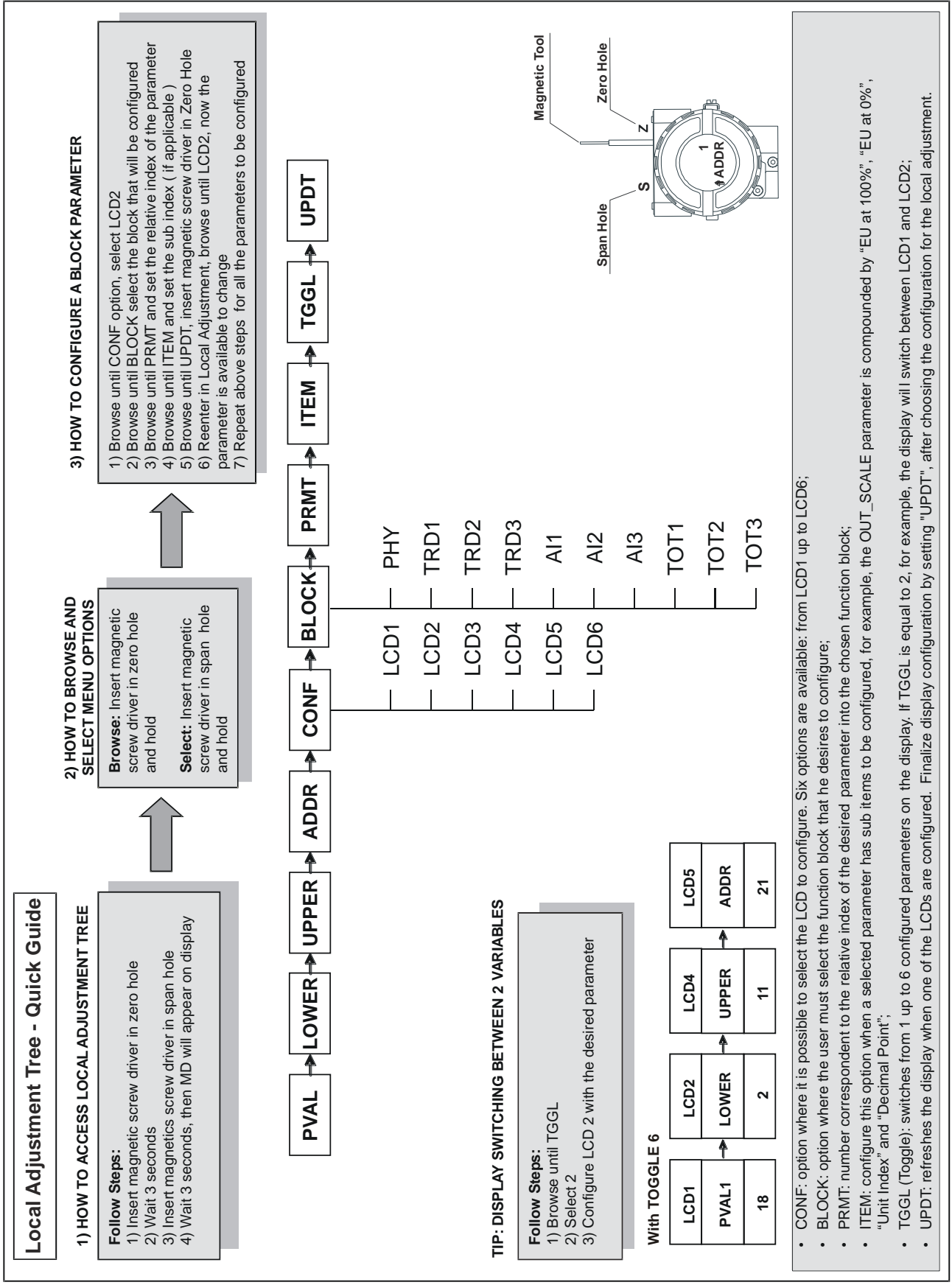

## J1 Jumper Connections

If J1 (see figure 3.20) is connected to ON, then simulation mode in the AO block is enabled.

## W1 Jumper Connections

If W1 (see figure 3.20) is connected to ON, the local adjustment programming tree is enabled and then important block parameters can be adjusted and communication can be pre-configured via local adjustment.

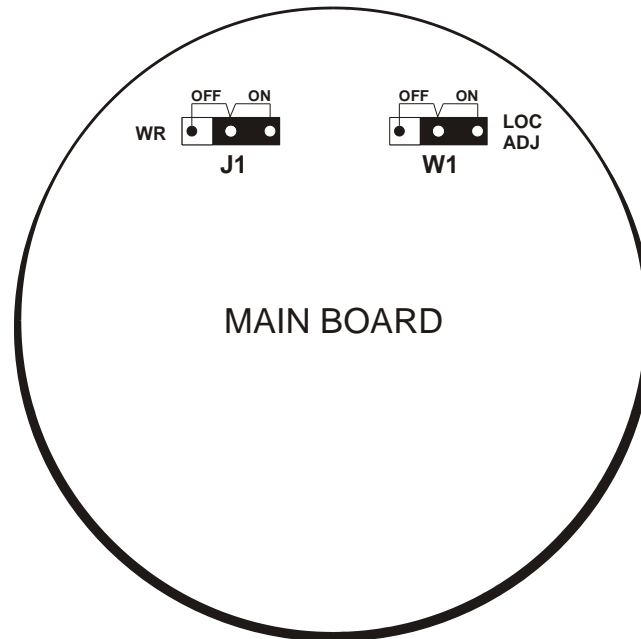

Fig. 3.36 - J1 and W1 Jumpers

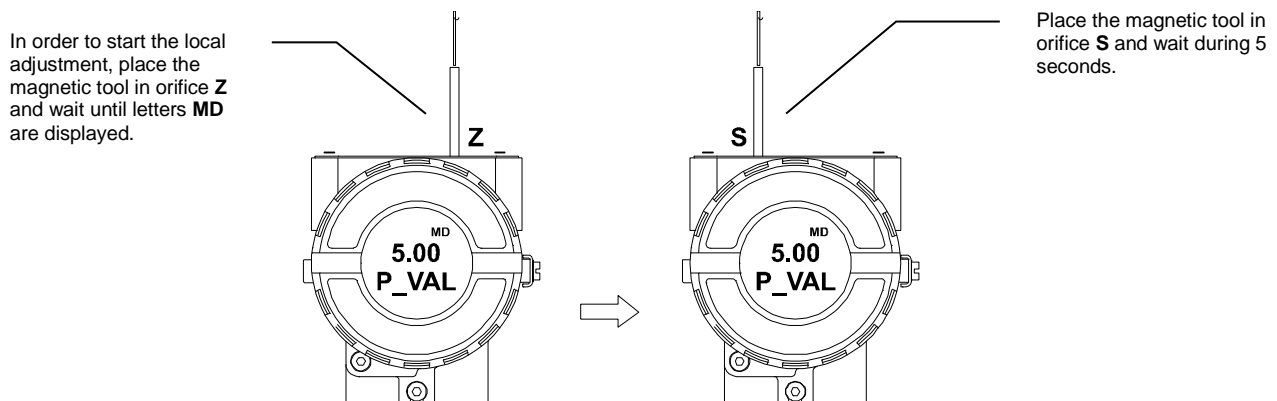
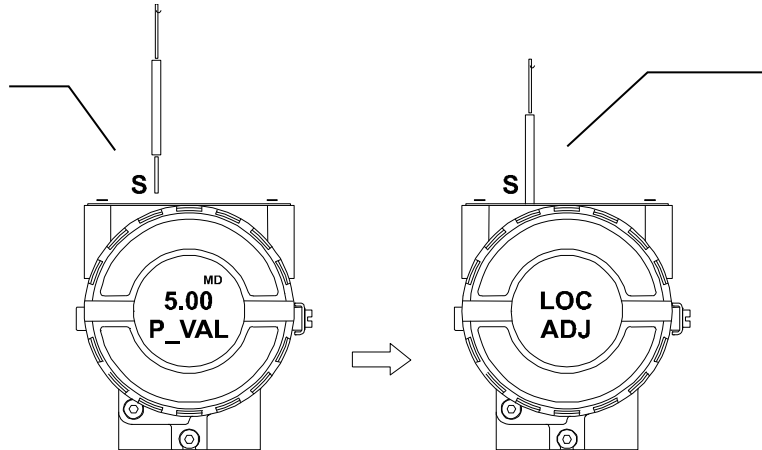

Figure 3.37 - Step 1 - IF303

Remove the magnetic tool from orifice **S**.



Insert the magnetic tool in orifice **S** once more and **LOC ADJ** should be displayed.

Figure 3.38 - Step 2 - IF303

Place the magnetic tool in orifice **Z**. In case this is the first configuration, the option shown on the display is the **TAG** with its corresponding mnemonic configured by the Configuration Tool. Otherwise, the option shown on the display will be the one configured in the prior operation. By keeping the tool inserted in this orifice, the local adjustment menu will rotate.

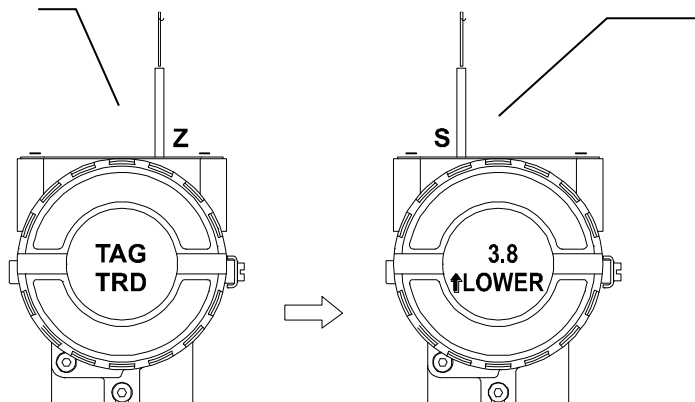

This parameter is used to calibrate the lower current point. In order to range the lower value, simply insert the magnetic tool in orifice **S** as soon as lower is shown on the display. An arrow pointing upward (↑) increment the value and an arrow pointing downward (↓) decrement the value. Apply the 4.00 mA current in the 1 and 4 terminals. Adjust the current showed on the display to 4.00 mA.

Figure 3.39 - Step 3 - IF303

In order to decrement the lower value, place the magnetic tool in orifice **Z** to shift the arrow to the downward position and then, by inserting and keeping the tool in orifice **S**, it is possible to decrement the lower value.

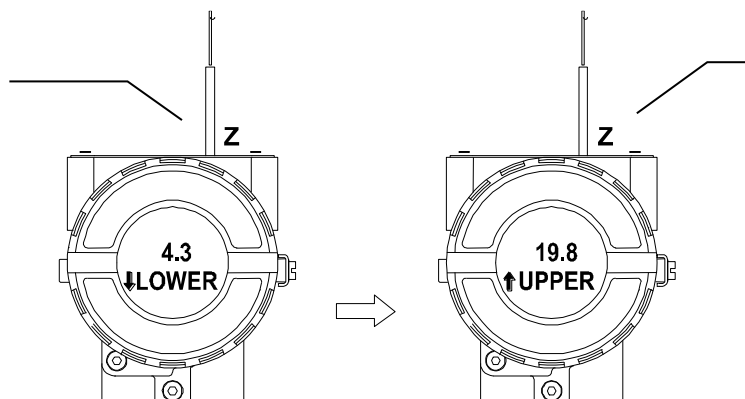

This parameter is used to calibrate the upper current point. In order to range the upper value, simply insert the magnetic tool in orifice **S** as soon as upper is shown on the display. An arrow pointing upward (↑) increment the value and an arrow pointing downward (↓) decrement the value. Apply the 20.0 mA current in the 1 and 4 terminals. Adjust the current showed on the display to 20.0 mA.

Figure 3.40 - Step 4 - IF303

In order to decrement the address value, place the magnetic tool in orifice Z to shift the arrow to the downward position and then, by inserting and keeping the tool in orifice S, it is possible to decrement the address value.

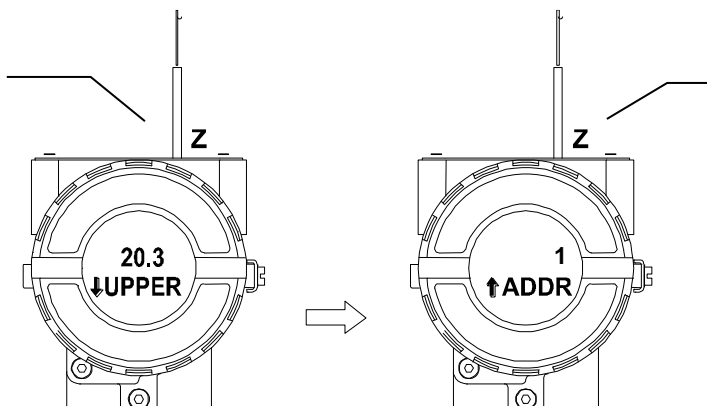

In order to change the address value, simply take off the magnetic tool from orifice Z as soon as ADDR is shown on the display. An arrow pointing upward (↑) increments the address and an arrow pointing downward (↓) decrements the address. In order to increment the address, insert the tool in S up to set the value desired.

Figure 3.41 - Step 5 - IF303

In order to decrement the address value, place the magnetic tool in orifice Z to shift the arrow to the downward position and then, by inserting and keeping the tool in orifice S, it is possible to decrement the address value.

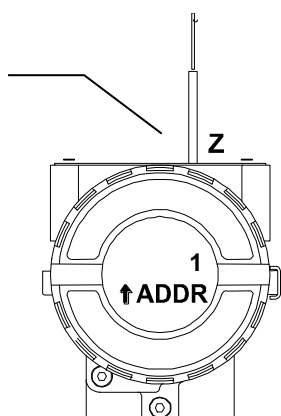

Figure 3.42 - Step 6 - IF303

**NOTE**

This Local adjustment configuration is a suggestion only. The user may choose his preferred configuration via Configuration Tool, simply configuring the display.

## Cyclical Diagnosis

Via cyclic communication is possible to verify diagnostics from the **IF303** using the Profibus Master Class 1 or even via acyclic communication via Master Class 2. The Profibus-PA devices provide up to 4 standard diagnoses bytes via Physical Block (see figure 3.43 and 3.44) and when the most significant bit of the fourth Byte is "1", the diagnose will extend the information in more 6 bytes. These Diagnosis bytes can also be monitored via cyclic tools.

Len of status bytes	Status Type	Physical Block Slot	Status		From Physical Block	
			Appears	Disappears	Standard Diagnostic	Extended Diagnostic
08 - Standard Diag 0E - Ext Diag	FE	01	01 - Appears 02 - Disappears		4 bytes	6 bytes vendor specific

When bit 55 ( byte 4, MSB ) is "1";  
the device has extended diagnostic

Figure 3.43 – Cyclical Diagnosis

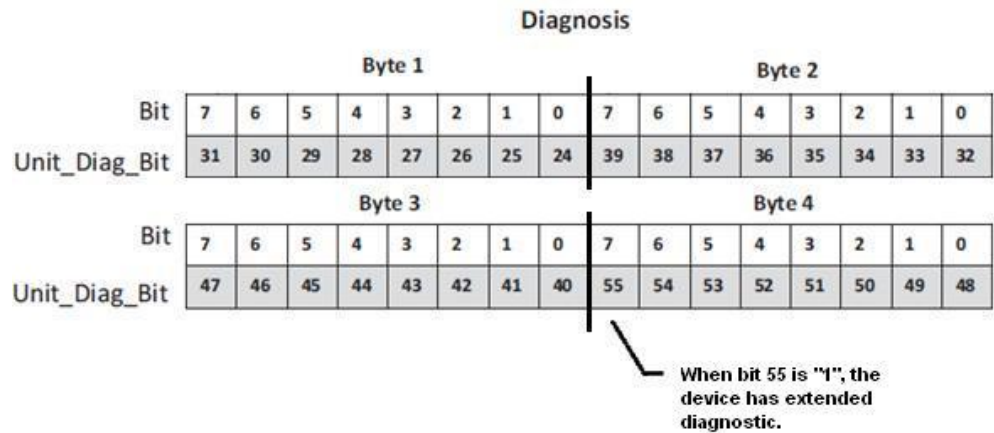

**Figure 3.44 – Cyclic Diagnosis mapping for 4 bytes of Physical Block.**

**Unit\_Diag\_bit** is described in the GSD file Profibus-PA device.

See below a description part of a GSD file for the 4 bytes and more detail:

```

;----- Description of device related diagnosis: -----
;
Unit_Diag_Bit(16) = "Error appears"
Unit_Diag_Bit(17) = "Error disappears"
;
;Byte 01
Unit_Diag_Bit(24) = "Hardware failure electronics"
Unit_Diag_Bit(25) = "Not used 25"
Unit_Diag_Bit(26) = "Not used 26"
Unit_Diag_Bit(27) = "Not used 27"
Unit_Diag_Bit(28) = "Memory error"
Unit_Diag_Bit(29) = "Measurement failure"
Unit_Diag_Bit(30) = "Device not initialized"
Unit_Diag_Bit(31) = "Device initialization failed"

;Byte 02
Unit_Diag_Bit(32) = "Not used 32"
Unit_Diag_Bit(33) = "Not used 33"
Unit_Diag_Bit(34) = "Configuration invalid"
Unit_Diag_Bit(35) = "Restart"
Unit_Diag_Bit(36) = "Coldstart"
Unit_Diag_Bit(37) = "Maintenance required"
Unit_Diag_Bit(38) = "Characteristics invalid"
Unit_Diag_Bit(39) = "Ident_Number violation"

;Byte 03
Unit_Diag_Bit(40) = "Not used 40"
Unit_Diag_Bit(41) = "Not used 41"
Unit_Diag_Bit(42) = "Not used 42"
Unit_Diag_Bit(43) = "Not used 43"
Unit_Diag_Bit(44) = "Not used 44"
Unit_Diag_Bit(45) = "Not used 45"
Unit_Diag_Bit(46) = "Not used 46"
Unit_Diag_Bit(47) = "Not used 47"

;byte 04
Unit_Diag_Bit(48) = "Not used 48"
Unit_Diag_Bit(49) = "Not used 49"
Unit_Diag_Bit(50) = "Not used 50"
Unit_Diag_Bit(51) = "Not used 51"
Unit_Diag_Bit(52) = "Not used 52"
    
```

---

```
Unit_Diag_Bit(53) = "Not used 53"
Unit_Diag_Bit(54) = "Not used 54"
Unit_Diag_Bit(55) = "Extension Available"

;Byte 05 TRD Block & PHY Block
Unit_Diag_Bit(56) = "TRD Block 1 Sensor Failure"
Unit_Diag_Bit(57) = "TRD Block 2 Sensor Failure"
Unit_Diag_Bit(58) = "TRD Block 3 Sensor Failure"
Unit_Diag_Bit(59) = "TRD Block 1 Range Violation"
Unit_Diag_Bit(60) = "TRD Block 2 Range Violation"
Unit_Diag_Bit(61) = "TRD Block 3 Range Violation"
Unit_Diag_Bit(62) = "Calibration Error - Check XD_ERROR parameter for TRD 1 or TRD 2 or TRD
3"
Unit_Diag_Bit(63) = "Device is in Writing Lock"

;byte 06 AI_1 Block
Unit_Diag_Bit(64) = "Simulation Active in AI 1 Block"
Unit_Diag_Bit(65) = "Fail Safe Active in AI 1 Block"
Unit_Diag_Bit(66) = "AI 1 Block in Out of Service"
Unit_Diag_Bit(67) = "AI 1 Block Output out of High limit"
Unit_Diag_Bit(68) = "AI 1 Block Output out of Low limit"
Unit_Diag_Bit(69) = "Not used 69"
Unit_Diag_Bit(70) = "Not used 70"
Unit_Diag_Bit(71) = "Not used 71"

;byte 07 AI_2 Block
Unit_Diag_Bit(72) = "Simulation Active in AI 2 Block"
Unit_Diag_Bit(73) = "Fail Safe Active in AI 2 Block"
Unit_Diag_Bit(74) = "AI 2 Block in Out of Service"
Unit_Diag_Bit(75) = "AI 2 Block Output out of High limit"
Unit_Diag_Bit(76) = "AI 2 Block Output out of Low limit"
Unit_Diag_Bit(77) = "Not used 77"
Unit_Diag_Bit(78) = "Not used 78"
Unit_Diag_Bit(79) = "Not used 79"

;byte 08 AI_3 Block
Unit_Diag_Bit(80) = "Simulation Active in AI 3 Block"
Unit_Diag_Bit(81) = "Fail Safe Active in AI 3 Block"
Unit_Diag_Bit(82) = "AI 3 Block in Out of Service"
Unit_Diag_Bit(83) = "AI 3 Block Output out of High limit"
Unit_Diag_Bit(84) = "AI 3 Block Output out of Low limit"
Unit_Diag_Bit(85) = "Not used 85"
Unit_Diag_Bit(86) = "Not used 86"
Unit_Diag_Bit(87) = "Not used 87"

;byte 09 TOT Block
Unit_Diag_Bit(88) = "TOT Block 1 in Out of Service"
Unit_Diag_Bit(89) = "Totalization 1 Out of High limit"
Unit_Diag_Bit(90) = "Totalization 1 Out of Low limit"
Unit_Diag_Bit(91) = "No assigned channel to TOT Block 1"
Unit_Diag_Bit(92) = "TRD Block 1 - Square Root function is active"
Unit_Diag_Bit(93) = "TOT Block 2 in Out of Service"
Unit_Diag_Bit(94) = "Totalization 2 Out of High limit"
Unit_Diag_Bit(95) = "Totalization 2 Out of Low limit"

;byte 10
Unit_Diag_Bit(96) = "No assigned channel to TOT Block 2"
Unit_Diag_Bit(97) = "TRD Block 2 - Square Root function is active"
Unit_Diag_Bit(98) = "TOT Block 3 in Out of Service"
Unit_Diag_Bit(99) = "Totalization 3 Out of High limit"
Unit_Diag_Bit(100) = "Totalization 3 Out of Low limit"
Unit_Diag_Bit(101) = "No assigned channel to TOT Block 3"
Unit_Diag_Bit(102) = "TRD Block 3 - Square Root function is active"
Unit_Diag_Bit(103) = "Not used 103"
```

**NOTE**

If the FIX flag is active on LCD, the IF303 is configured to "Profile Specific". When in "Manufacturer Specific", the Identifier Number is 0x0896. Once the Identifier\_Number\_Selector is changed from "Profile Specific" to "Manufacturer Specific" or vice-versa, you must wait 5 seconds while it is saved and then turn off the IF303 and then the identifier is updated in the level of communication. If the equipment is in "Profile Specific" and using the GSD file Identifier Number equals 0x0896, the acyclic communication will work well with tools based on EDDL, FDT/DTM, but no cyclic communication with the Profibus-DP master will get success.



# Section 4

## MAINTENANCE PROCEDURES

### General

NOTE
Equipment installed in hazardous atmospheres must be inspected in compliance with the IEC60079-17 standard.

SMAR **IF303** Current to PROFIBUS PA Converters are extensively tested and inspected before delivery to the end user. Nevertheless, during their design and development, consideration was given to the possibility of repairs by the end user, if necessary.

In general, it is recommended that the end user do not try to repair printed circuit boards. Instead, he should have spare circuit boards, which may be ordered from SMAR whenever necessary.

### Troubleshooting

SYMPTOM	PROBABLE SOURCE OF PROBLEM
<b>No Quiescent Current</b>	<p><b>Converter PROFIBUS Connections</b> Check wiring polarity and continuity.</p> <p><b>Power Supply</b> Check power supply output. The voltage at the IF303 terminals must be between 9 and 32 Vdc.</p> <p><b>Electronic Circuit Failure</b> Check the boards for defect by replacing them with spare ones.</p>
<b>No Communications</b>	<p><b>Network Connections</b> Check the network connections: devices, power supply, couplers, links, and terminators.</p> <p><b>Transmitter Configuration</b> Check configuration of communication parameters of converter.</p> <p><b>Network Configuration</b> Check communication configuration of the network.</p> <p><b>Electronic Circuit Failure</b> Try to replace the converter circuit with spare parts.</p>
<b>Incorrect Input</b>	<p><b>Input Terminals Connection</b> Check wiring polarity and continuity.</p> <p><b>Conventional Transmitter</b> Verify if the conventional transmitter is working properly or if it has the necessary voltage. Remember that IF303 has a 100 Ohms plus 0.8 V input impedance.</p> <p><b>Calibration</b> Check calibration of IF303 and the conventional transmitters.</p>

If the problem is not presented in the table above follow the Note below:

<b>NOTE</b>
<p>The Factory Init should be tried as a last option to recover the equipment control when the equipment presents some problem related to the function blocks or the communication. <b>This operation must only be carried out by authorized technical personnel and with the process offline, since the equipment will be configured with standard and factory data.</b></p> <p>This procedure resets all the configurations run on the equipment, after which a partial download should be performed. With exception to the equipment physical address and the gsd identifier number selector parameter. After doing this, all configurations must be remade according to their applications.</p> <p>To run the factory Init, use two magnetic screwdrivers. Remove the screw on the equipment that fixes the identification tag on the carcass top to access the orifices bearing the letters "S" and "Z".</p> <p>The operations to follow are:</p> <ol style="list-style-type: none"> <li>1) Turn off the equipment; insert the magnetic tools in each orifice (S and Z). Leave them in the orifices;</li> <li>2) Power the equipment;</li> <li>3) As soon as Factory Init is shown on the display, take off the tools and wait for the "5" symbol on the right upper corner of the display to unlit, thus indicating the end of the operation.</li> </ol> <p>This operation has factory configuration that eliminates possible problems with the functional blocks or the transmitter communication.</p>

## Disassembly Procedure

Refer to Figure 4.1 - IF303 Exploded View Make sure to disconnect power supply before disassembling the converter.

To remove the circuit boards (5 and 7) and display (4), first loose the cover locking (8) on the side not marked "Field Terminals", then unscrew the cover (1).



<b>WARNING</b>
<p>The boards have CMOS components, which may be damaged by electrostatic discharges. Observe correct procedures for handling CMOS components. It is also recommended to store the circuit boards in electrostatic-proof cases.</p>

Loose the two screws (3) that anchor the display and the main circuit board. Gently pull out the display, and then the main board (5). To remove the input board (7), first unscrew the two screws (6) that anchors it to the housing (9), and gently pull out the board.

## Reassembly Procedure

- Put input board (7) into housing (9).
- Anchors input board with their screws (6).
- Put main board (5) into the housing, ensuring all inter connecting pins are connected.
- Put display (4) into the housing, observing the four mounting positions. "▲" should point in the direction desired as UP.
- Anchors main board and display with their screws (3).
- Fit the cover (1) and lock it using the locking screw (8).

## Boards Interchangeability

Main and input boards are supposed to stay together, because calibration data from input board circuit is stored in EEPROM of the main board.



**WARNING**

If, for some reason, you separate the input and the main boards, you must do a trim to guarantee precision of the inputs. With mismatched boards, the factory trim will not be as good as it was.

## Exploded View

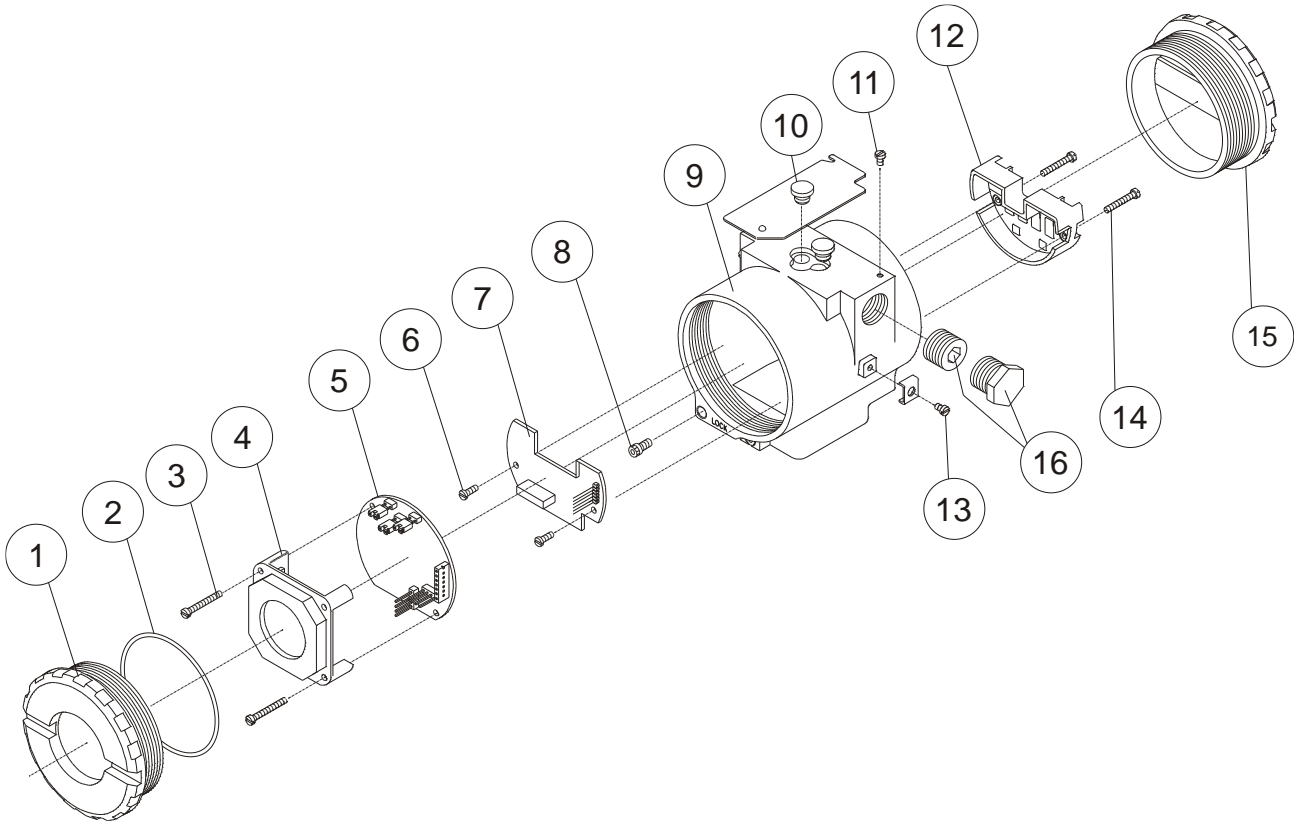

Figure 4.1 - IF303 Exploded View

## Accessories and Related Products

ACCESSORIES AND RELATED PRODUCTS	
ORDERING CODE	DESCRIPTION
AssetView FDT	Asset Management With FDT
BC1	Fieldbus/RS232 Interface
BT302	Terminator
DF47-17	Intrinsic Safety Barrier
DF73	HSE/PROFIBUS-DP Controller
DF95/DF97	PROFIBUS DP/PA Controller
FDI302	Field Device interface
PBI	USB Profibus Interface
ProfibusView	Profibus PA Device Parameterization Software
PS302/DF52	Power Supply
PSI302/DF53	Power Supply Impedance
SD1	Magnetic Tool for Local Adjustment

## Spare Parts List

SPARE PARTS LIST				
	DESCRIPTION OF PARTS	POSITION	CODE	CATEGORY (NOTE 4)
Cover Without Window (Includes O-Ring)	Aluminum	1 and 15	204-0102	
	316 SS	1 and 15	204-0105	
Cover With Window For Indication (Includes O-Ring)	Aluminum	1	204-0103	
	316 SS	1	204-0106	
O-rings <b>(Note 2)</b>	Cover, Buna-N	2	204-0122	<b>B</b>
Aluminum Housing Main Board Screw	Units With Indicator	3	304-0118	
	Units Without Indicator	3	304-0117	
316 Stainless Steel Housing Main Board Screw	Units With Indicator	3	204-0118	
	Units Without Indicator	3	204-0117	
Digital Indicator		4	214-0108	
Main and Input Circuit Board Assembly		5 and 7	400-0311	<b>A</b>
Input Board Screw	Housing in Aluminum	6	314-0125	
	Housing in 316 Stainless Steel	6	214-0125	
Cover Locking Screw		8	204-0120	
Housing, Aluminum <b>(Note 1)</b>	½ - 14 NPT	9	400-0305	
	M20 x 1.5	9	400-0306	
	PG 13.5 DIN	9	400-0307	
Housing, 316 SS <b>(Note 1)</b>	½ - 14 NPT	9	400-0308	
	M20 x 1.5	9	400-0309	
	PG 13.5 DIN	9	400-0310	
Local Adjustment Protection Cap		10	204-0114	
Identification Plate Fixing Screw		11	204-0116	
Terminal Insulator		12	314-0123	
External Ground Screw		13	204-0124	
Terminal Holding Screw	Housing in Aluminium	14	304-0119	
	Housing in 316 Stainless Steel	14	204-0119	
Six-Sided Plug 1/2" NPT Internal BR Ex	Bichromated Carbon Steel	16	400-0808	
	Bichromated 304 Stainless Steel	16	400-0809	
Six-Sided Plug 1/2" NPT Internal	Bichromated Carbon Steel	16	400-0583-11	
	Bichromated 304 Stainless Steel	16	400-0583-12	
Six-Sided Plug M20 X 1.5 External BR Ex d	316 Stainless Steel	16	400-0810	
Six-Sided Plug PG13.5 External BR Ex d	316 Stainless Steel	16	400-0811	
Mounting Bracket for 2" Pipe <b>(Note 3)</b>	Carbon Steel	-	214-0801	
	316 Stainless Steel	-	214-0802	
	Carbon Steel Bolts, Nuts, Washers and U-clamp in Stainless Steel	-	214-0803	

### NOTE

1. It includes terminal holder insulator, bolts (cover lock, grounding and terminal holder insulator) and identification plate without certification.
2. O-Rings are packaged in packs of 12 units.
3. Including U-clamp, nuts, bolts and washers. Spare Parts List.
4. For category A, it is recommended to keep, in stock, 25 parts installed for each set, and for category B, 50.

## Section 5

# TECHNICAL CHARACTERISTICS

Functional Specifications	
<b>Input Signal (Field Values)</b>	0-20 mA, 4-20 mA or any within 0 and 20 mA. Reverse polarity protected (*).
<b>Output Signal (Communication)</b>	PROFIBUS PA, Digital only, complies with IEC 61158-2 (H1): 31.25 Kbit/s and voltage mode with bus power.
<b>Input Impedance</b>	Resistive 100, plus a 0.8 V drop over diode in forward direction.
<b>Power Supply</b>	Bus power 9-32 Vdc. Current consumption quiescent 12 mA.
<b>Indication</b>	Optional 4½ digit LCD indicator.
<b>Hazardous Area Certification</b>	Explosion-proof and intrinsically safe (ATEX (NEMKO and DEKRA EXAM), FM, CEPEL, CSA and NEPSI).  Designed to comply with European Regulations (ATEX 94/9/EC and LVD 2006/95/EC).
<b>Temperature Limits</b>	Operation: -40 to 85 °C (-40 to 185 °F) Storage: -40 to 120 °C (-40 to 250 °F) Display: -10 to 60 °C ( 14 to 140 °F) operation -40 to 85 °C (-40 to 185 °F) without damage.
<b>Humidity Limits</b>	0 to 100% RH.
<b>Turn-on Time</b>	Approximately 10 seconds.
<b>Update Time</b>	Approximately 0.5 second.
<b>Configuration</b>	Basic configuration may be done using local adjustment magnetic tool if device is fitted with display. Complete configuration is possible using PC software interface, by using a configurator (Ex.: ProfibusView, AssetView for FDT or Simatic PDM).
Performance Specifications	
<b>Accuracy</b>	0.03%. of span for 4-20 mA, 5 µA for others spans.
<b>Ambient Temperature Effect</b>	For a 10° C variation: ± 0.05%.
<b>Vibration Effect</b>	Complies with SAMA PMC 31.1.
<b>Electromagnetic Interference Effect</b>	Designed to comply with European Directive EMC 2004/108/EC.
Physical Specifications	
<b>Hardware</b>	Physical: according to IEC 61158-2 and conformity with the FISCO model.
<b>Electrical Connection</b>	1/2-14 NPT, PG 13.5 or M20 x 1.5.
<b>Material of Construction</b>	Injected low copper aluminum with polyester painting or 316 Stainless Steel housing, with Buna N O-rings on cover.
<b>Mounting</b>	With an optional bracket can be installed on a 2" pipe or fixed on a wall or panel.
<b>Weight</b>	Without display and mounting bracket: 0.80 kg. Add for digital display: 0.13 kg. Add for mounting bracket: 0.60 kg.

### \* WARNING

Apply in the inputs of the conversor only current levels. **Don't apply tension levels**, because the shunt resistors are of 100R 1W and **tension above 10 Vdc it can damage them.**

## Ordering Code

MODEL	
IF303	TRIPLE CHANNEL CURRENT TO PROFIBUS CONVERTER
COD.	Local Indicator
0	Without indicator
1	With indicator
COD.	Mounting Bracket
0	Without Bracket
1	Carbon Steel. Accessories: Carbon Steel
2	316 Stainless Steel. Accessories: Al316
7	Carbon Steel. Accessories: Al316
COD.	Electrical Connections
0	1/2" - 14 NPT
1	1/2" - 14 NPT X 3/4 NPT (AI 316) - with adapter
2	1/2" - 14 NPT X 3/4 BSP (AI 316) - with adapter
3	1/2" - 14 NPT X 1/2 BSP (AI 316) - with adapter
A	M20 X 1.5
B	PG 13.5 DIN
SPECIAL OPTIONS	
COD.	Housing
H0	Aluminum (IP/TYPE)
H1	316 Stainless Steel (IP/TYPE)
H2	Aluminum for saline atmosphere (IPW/TYPE X)
H3	316 Stainless Steel for saline atmosphere (IPW/TYPE X)
COD.	Identification Plate
I1	FM: XP, IS, NI, DI
I3	CSA: XP, IS, NI, DI
I4	EXAM (DMT): Ex-ia; NEMKO: Ex-d
I5	CEPEL: EX-D, Ex-ia
I6	Without Certification
IE	NEPSI: Ex-ia
COD.	Painting
P0	Gray Munsell N 6,5 Polyester
P3	Black Polyester
P4	White Epoxi
P5	Yellow Polyester
P8	Without Painting
P9	Safety Blue Epoxy - Electrostatic Painting
PC	Safety Blue Polyester - Electrostatic Painting
PG	Safety Orange Epoxi Paint - Electrostatic Painting
COD.	Input Signal
T0	3 output, 4 to 20 mA
COD.	Tag Plate
J0	With tag
J1	Blank
J2	According to user's notes
COD.	Special
ZZ	See Notes

IF303	1	1	0	*	*	*	*	*	*
-------	---	---	---	---	---	---	---	---	---

← TYPICAL MODEL

\* Leave it blank for no optional items.

## CERTIFICATIONS INFORMATION

### *European Directive Information*

Consult [www.Smar.com](http://www.Smar.com) for the EC declarations of conformity and certificates.

**Authorized representative/importer located within the Community:**

Smar Europe BV De Oude Wereld 116 2408 TM Alphen aan den Rijn Netherlands

**ATEX Directive 2014/34/EU - "Equipment for explosive atmospheres" (applicable from 20 April 2016)**

The EC-Type Examination Certificate is released by DNV Product Assurance AS (NB 2460) and DEKRA Testing and Certification GmbH (NB 0158).

Designated certification body that monitors manufacturing and released QAN (Quality Assurance Notification) is UL International Demko AS (NB 0539).

**LVD Directive 2014/35/EU – "Low Voltage" (applicable from 20 April 2016)**

According to the LVD directive Annex II, electrical equipment for use in an explosive atmosphere is outside the scope of this directive.

According to IEC standard: IEC 61010-1 - Safety requirements for electrical equipment for measurement, control, and laboratory use - Part 1: General requirements.

**ROHS Directive 2011/65/EU - "Restriction of the use of certain hazardous substances in electrical and electronic equipment"**

For the evaluation of the products the following standards were consulted: EN IEC 63000.

**EMC Directive 2014/30/EU - "Electromagnetic Compatibility" (applicable from 20 April 2016)**

For products evaluation the standard IEC 61326-1 were consulted and to comply with the EMC directive the installation must follow these special conditions:

Use shielded, twisted-pair cable for powering the instrument and signal wiring.

Keep the shield insulated at the instrument side, connecting the other one to the ground.

### *Hazardous locations general information*

**Ex Standards:**

IEC 60079-0 General Requirements

IEC 60079-1 Flameproof Enclosures "d"

IEC 60079-7 Increased Safe "e"

IEC 60079-11 Intrinsic Safety "i"

IEC 60079-18 Encapsulation "m"

IEC 60079-26 Equipment with Separation Elements or combined Levels of Protection

IEC 60079-31 Equipment dust ignition protection by enclosure "t"

IEC 60529 Classification of degrees of protection provided by enclosures (IP Code)

IEC 60079-10 Classification of Hazardous Areas

IEC 60079-14 Electrical installation design, selection and erection

IEC 60079-17 Electrical Installations, Inspections and Maintenance

IEC 60079-19 Equipment repair, overhaul and reclamation

ISO/IEC 80079-34 Application of quality systems for equipment manufacture

**Warning:**

**Explosions could result in death or serious injury, besides financial damage.**

Installation of this instrument in hazardous areas must be in accordance with the local standards and type of protection. Before proceedings with installation make sure that the certificate parameters are in accordance with the classified hazardous area.

**Maintenance and Repair**

The instrument modification or replaced parts supplied by any other supplier than authorized representative of Smar is prohibited and will void the Certification.

**Marking Label**

The instrument is marked with type of protection options. The certification is valid only when the type of protection is indicated by the user. Once a particular type of protection is installed, do not reinstall it using any other type of protection.

**Intrinsic Safety / Non Incendive application**

Only connect the equipment with the "Intrinsic safety" protection type to a circuit intrinsically safe. If the equipment has already been used in circuits not intrinsically safe or if the electrical specifications have not been respected, the safety of the equipment is no longer guaranteed for "Intrinsic Safety" installations.

In hazardous areas with intrinsic safety or non-incendive requirements, the circuit entity parameters and applicable installation procedures must be observed.

The instrument must be connected to a proper intrinsic safety barrier. Check the intrinsically safe parameters involving the barrier and equipment including the cable and connections. Associated apparatus ground bus shall be insulated from panels and mounting enclosures. Shield is optional, when using shielded cable, be sure to insulate the end not grounded.

Cable capacitance and inductance plus Ci and Li must be smaller than Co and Lo of the Associated Apparatus.

It is recommended do not remove the housing covers when powered on.

**Explosionproof / Flameproof application**

Only use Explosionproof/Flameproof certified Plugs, Adapters and Cable glands.

The electrical connections entries must be connected using a conduit with sealed unit or closed using metal cable gland or metal blanking plug with at least IP66.

Do not remove the housing covers when powered on.

**Enclosure**

The electronic housing and sensor threads installed in hazardous areas must have a minimum of 6 fully engaged threads. The covers must be tightened with at least 8 turns, to avoid the penetration of humidity or corrosive gases, and until it touches the housing. Then, tighten more 1/3 turn (120°) to guarantee the sealing.

Lock the housing and covers using the locking screw.

The enclosure contains aluminum and is considered to present a potential risk of ignition by impact or friction.

Care must be taken during installation and use to prevent impact or friction.

**Degree of Protection of enclosure (IP)**

IPx8: Second numeral meaning continuous immersion in water under special condition defined as 10m for a period of 24 hours (Ref: IEC60529).

IPW/ TypeX: Supplementary letter W or X meaning special condition defined as saline environment tested in saturated solution of NaCl 5% w/w at 35°C for a period of 200 hours (Ref: NEMA 250/ IEC60529).

For enclosure with IP/IPW/TypeX applications, all NPT threads must apply a proper water-proof sealant (a non-hardening silicone group sealant is recommended).



## Hazardous Locations Approvals

### FM Approvals

FM OD7A9.AX

IS Class I, II, III Division 1, Groups A, B, C and D, E, F, G

XP Class I, Division 1, Groups A, B, C, D

DIP Class II, III Division 1, Groups E, F, G

NI Class I, Division 2, Groups A, B, C, D

T4; Ta = -25°C < Ta < 60°C; Type 4, 4X, 6

Entity Parameters Fieldbus Power Supply Input (report 3015629):

Vmax = 24 Vdc, I<sub>max</sub> = 250 mA, P<sub>i</sub> = 1.2 W, C<sub>i</sub> = 5 nF, L<sub>i</sub> = 12 uH

Vmax = 16 Vdc, I<sub>max</sub> = 250 mA, P<sub>i</sub> = 2 W, C<sub>i</sub> = 5 nF, L<sub>i</sub> = 12 uH

4-20 mA Current Loop:

Vmax = 30 Vdc, I<sub>max</sub> = 110 mA, P<sub>i</sub> = 0,825 W, C<sub>i</sub> = 5 nF, L<sub>i</sub> = 12 uH

Drawing 102A-0081, 102A-1211, 102A-1334, 102A-1628, 102A-1629

### ATEX DNV

Explosion Proof (PRESAFE 20 75160X)

II 2G Ex db IIC T6 Gb

Ambient Temperature: -20 °C to +60 °C

Options: IP66W/68W or IP66/68

Special conditions for safe use:

Repairs of the flameproof joints must be made in compliance with the structural specifications provided by the manufacturer. Repairs must not be made on the basis of values specified in tables 1 and 2 of EN/IEC 60079-1.

The Essential Health and Safety Requirements are assured by compliance with:

EN IEC 60079-0:2018 General Requirements

EN 60079-1:2014 Flameproof Enclosures “d”

Drawing 102A-1417, 102A-1499

### IECEX DNV

Explosion Proof (IECEX DNV 21.0090X)

Ex db IIC T6 Gb

Ambient Temperature: -20 °C to +60 °C

Options: IP66/68W or IP66/68

Special Conditions for Safe Use

Repairs of the flameproof joints must be made in compliance with the structural specifications provided by the manufacturer. Repairs must not be made on the basis of values specified in tables 1 and 2 of EN/IEC 60079-1.

The Essential Health and Safety Requirements are assured by compliance with:

IEC 60079-0:2017 General Requirements

IEC 60079-1:2014-06 Equipment protection by flameproof enclosures “d”

Drawing 102A-2196, 102A-2197

### DEKRA

Intrinsic Safety (DMT 00 ATEX E 064)

I M2 Ex ia I Mb

II 2G Ex ia IIC T4/T5/T6 Gb

Supply circuit for the connection to an intrinsically safe FISCO fieldbus-circuit:

U<sub>i</sub> = 24Vdc, I<sub>i</sub> = 380 mA, P<sub>i</sub> = 5.32 W, C<sub>i</sub> ≤ 5 nF, L<sub>i</sub> = neg

Parameters of the supply circuit comply with FISCO model according to Annex G EN 60079-11:2012, replacing EN 60079-27: 2008.

Input-signal-circuits:

three 0-20 mA or 4-20 mA signal inputs with common ground

Input impedance (load impedance) R<sub>i</sub> 100 Ω

Effective internal capacitance C<sub>i</sub> negligible

Effective internal inductance L<sub>i</sub> negligible

Safety relevant maximum values for certified intrinsically safe 0-20 mA or 4-20 mA signal circuits as a function of ambient temperature and temperature class

Max. Ambient temperature Ta	Temperature Class	Voltage DC Ui	Current Ii	Power Pi
60°C	T4	28 V	93 mA	750 mW
50°C	T5	28 V	93 mA	750 mW
40°C	T6	28 V	93 mA	570 mW

The signal inputs are safely galvanically separated from the fieldbus circuit.  
Ambient Temperature:  $-40^{\circ}\text{C} \leq T_a \leq +60^{\circ}\text{C}$

The Essential Health and Safety Requirements are assured by compliance with:  
EN 60079-0:2012 + A11:2013 General Requirements  
EN 60079-11:2012 Intrinsic Safety "i"

Drawing 102A-1417, 102A-1499, 102A-1418, 102A-1500

#### **INMETRO NCC**

Segurança Intrínseca (NCC 24.0169X)

Equipamento de campo FISCO

Ex ia IIC T\* Ga

Ex ia IIIC T\* Da

Ui = 30 V li = 380 mA Pi = 5,32 W Ci = 5,0 nF Li = desp

Tamb:  $-20^{\circ}\text{C}$  a  $+50^{\circ}\text{C}$  para T5 ou T<sub>200</sub>100 °C

Tamb:  $-20^{\circ}\text{C}$  a  $+65^{\circ}\text{C}$  para T4 ou T<sub>200</sub>135 °C

IP66/68 ou IP66/68W

Prova de Explosão (NCC 24.0144)

Ex db IIC T6 Gb

Ex tb IIIC T85 °C Db

Tamb:  $-20^{\circ}\text{C}$  a  $+40^{\circ}\text{C}$

IP66/68 ou IP66/68W

#### Observações:

O número do certificado é finalizado pela letra "X" para indicar que para a versão do Conversor de Corrente para Protocolo FIELDBUS/PROFIBUS PA, modelos IF302 e IF303 equipado com invólucro fabricado em liga de alumínio, somente pode ser instalado em localização que exigem o "EPL Ga", se durante a instalação for excluído o risco de ocorrer impacto ou fricção entre o invólucro e peças de ferro/aço.

O produto adicionalmente marcado com a letra suplementar "W" indica que o equipamento foi ensaiado em uma solução saturada a 5% de NaCl p/p, à 35 °C, pelo tempo de 200 h e foi aprovado para uso em atmosferas salinas, condicionado à utilização de acessórios de instalação no mesmo material do equipamento e de bujões de aço inoxidável ASTM-A240, para fechamento das entradas roscadas não utilizadas.

Os planos de pintura P1 são permitidos apenas para equipamento fornecido com plaqueta de identificação com marcação para grupo de gás IIB.

O grau de proteção IP68 só é garantido se nas entradas roscadas de ½" NPT for utilizado vedante não endurecível à base de silicone.

O segundo numeral oito indica que o equipamento foi ensaiado para uma condição de submersão de dez metros por vinte e quatro horas. O acessório deve ser instalado em equipamentos com grau de proteção equivalente.

É responsabilidade do fabricante assegurar que todos os transformadores da placa analógica tenham sido submetidos com sucesso aos ensaios de rotina de 1500 V durante um minuto.

Este certificado é válido apenas para os produtos dos modelos avaliados. Qualquer modificação nos projetos, bem como a utilização de componentes ou materiais diferentes daqueles definidos pela documentação descritiva dos produtos, sem a prévia autorização, invalidará este certificado.

As atividades de instalação, inspeção, manutenção, reparo, revisão e recuperação dos equipamentos são de responsabilidade dos usuários e devem ser executadas de acordo com os requisitos das normas técnicas vigentes e com as recomendações do fabricante.

#### Normas Aplicáveis:

ABNT NBR IEC 60079-0:2020 Atmosferas explosivas - Parte 0: Equipamentos – Requisitos gerais

ABNT NBR IEC 60079-1:2016 Atmosferas explosivas - Parte 1: Proteção de equipamento por invólucro à prova de explosão "d"

ABNT NBR IEC 60079-11:2013 Atmosferas explosivas - Parte 11: Proteção de equipamento por segurança intrínseca "i"

ABNT NBR IEC 60079-26:2022 Atmosferas explosivas - Parte 26: Equipamentos com elementos de separação ou níveis de proteção combinados

ABNT NBR IEC 60079-31:2022 Atmosferas explosivas - Parte 31: Proteção de equipamentos contra ignição de poeira por invólucros "t"  
ABNT NBR IEC 60529:2017 Graus de proteção providos por invólucros (Código IP)

Desenhos 102A1369, 102A1249, 102A2022, 102A2021, 102A2083

## Identification Plate

### FM Approvals

**smar** IF303 4-20mA to FB Converter  
BR - 14160  
Made in Brazil

Temp. Class:	T4	XP	CL I, DIV 1, GP A,B,C,D.
Tamb.	60°C max.	DIP	CL II,III, DIV 1, GP E,F,G.
Vmax.	24 VDC	S	CL III, DIV 1.
I max.	250 mA	IS	CL I,II,III, DIV 1, GP A,B,C,D,E,F,G.
Ci	5 nF	NI	CL I, DIV 2, GP A,B,C,D.
Li	12 uH		Per inst. dwg 102A0081.

APPROVED FM Type 4X/6/6P

0044333 - 2007 PROFIBUS-PA CE 121100

**smar** IF303 4-20mA to FB Converter  
BR - 14160  
Made in Brazil

Temp. Class:	T4	XP	CL I, DIV 1, GP A,B,C,D.
Tamb.	60°C max.	DIP	CL II,III, DIV 1, GP E,F,G.
Vmax.	24 VDC	S	CL III, DIV 1.
I max.	250 mA	IS	CL I,II,III, DIV 1, GP A,B,C,D,E,F,G.
Ci	5 nF	NI	CL I, DIV 2, GP A,B,C,D.
Li	12 uH		Per inst. dwg 102A0081.

APPROVED FM Type 4/6/6P

0044333 - 2007 PROFIBUS-PA CE 133400

### ATEX/ IECEx

**smar** IF303 4-20mA to FB Converter  
Nova Smar S/A  
Av. Dr. Antônio Furlan Jr.  
1028 Sertãozinho-SP  
14170-480  
Brazil

Ex II 2G Ex ia IIC T4/T5/T6 Gb DMT 00 ATEX E 064 ( )  
Pi = 5,32 W -40°C ≤ Ta ≤ +60°C  
Ui = 24 VDC li = 380 mA Li = neg Ci ≤ 5 nF

Ex II 2G Ex db IIC T6 Gb PRESAFE 20 ATEX 75160X ( )  
Tamb = -20°C to 60°C U = 28 VDC

IP66  
IP68 10m/24h

0000000 - 0000 PROFIBUS-PA CE 0470 141705

**smar** IF303 4-20mA to FB Converter  
Nova Smar S/A  
Av. Dr. Antônio Furlan Jr.  
1028 Sertãozinho-SP  
14170-480  
Brazil

Ex II 2G Ex ia IIC T4/T5/T6 Gb DMT 00 ATEX E 064 ( )  
Pi = 5,32 W -40°C ≤ Ta ≤ +60°C  
Ui = 24 VDC li = 380 mA Li = neg Ci ≤ 5 nF

Ex II 2G Ex db IIC T6 Gb PRESAFE 20 ATEX 75160X ( )  
Tamb = -20°C to 60°C U = 28 VDC

IP66W  
IP68W 10m/24h

0000000 - 0000 PROFIBUS-PA CE 0470 149905

**smar** IF303 4-20mA to FB Converter  
Nova Smar S/A  
Av. Dr. Antônio Furlan Jr.  
1028 Sertãozinho-SP  
14170-480  
Brazil

Ex db IIC T6 Gb IECEx DNV 21.0090X ( )  
Tamb = -20°C to 60°C  
U = 28 VDC

IP66  
IP68 10m/24h

0000000 - 0000 PROFIBUS-PA CE 0470 219600

**smar** IF303 4-20mA to FB Converter  
Nova Smar S/A  
Av. Dr. Antônio Furlan Jr.  
1028 Sertãozinho-SP  
14170-480  
Brazil

Ex db IIC T6 Gb IECEx DNV 21.0090X ( )  
Tamb = -20°C to 60°C  
U = 28 VDC

IP66W  
IP68W 10m/24h

0000000 - 0000 PROFIBUS-PA CE 0470 219700

**smar** IF303 4-20mA to FB Converter  
BR - 14160  
Sertãozinho  
Brazil

Ex I M2 Ex ia I Mb DMT 00 ATEX E 064  
-40°C ≤ Ta ≤ +60°C  
Pi = 5,32 W  
Ui = 24 VDC li = 380 mA Li = neg Ci ≤ 5 nF

IP 66 68

0000000 - 0000 PROFIBUS-PA CE 0470 141801

**smar** IF303 4-20mA to FB Converter  
BR - 14160  
Sertãozinho  
Brazil

Ex I M2 Ex ia I Mb DMT 00 ATEX E 064  
-40°C ≤ Ta ≤ +60°C  
Pi = 5,32 W  
Ui = 24 VDC li = 380 mA Li = neg Ci ≤ 5 nF

IP 66 W 68 W

0000000 - 0000 PROFIBUS-PA CE 0470 150001

### INMETRO NCC

**smar** IF303 Conversor 4-20mA FB  
Nova Smar SA Av. Dr. Antônio Furlan Jr, 1028 | Sertãozinho - SP - Brasil | 14170-480

Segurança

Ex db IIC T6 Gb NCC 24.0144 ( )  
Ex ia IIC T4/T5 Ga NCC 24.0169 X ( )  
Tamb = -20° a 65°C (T4) -20° a 50°C (T5)  
Ui = 30V li = 380mA Pi = 5,32W Ci = 5nF Li = desp  
FISCO Field Device IP66W ou IP68W 10m/24h

0000000 - 0000 PROFIBUS-PA CE 124905

**smar** IF303 Conversor 4-20mA FB  
Nova Smar SA Av. Dr. Antônio Furlan Jr, 1028 | Sertãozinho - SP - Brasil | 14170-480

Segurança

Ex db IIC T6 Gb NCC 24.0144 ( )  
Ex ia IIC T4/T5 Ga NCC 24.0169 X ( )  
Tamb = -20° a 65°C (T4) -20° a 50°C (T5)  
Ui = 30V li = 380mA Pi = 5,32W Ci = 5nF Li = desp  
FISCO Field Device IP66W ou IP68W 10m/24h

0000000 - 0000 PROFIBUS-PA CE 136905

**smar IF303 Conversor 4-20mA FB**  
 Nova Smar SA Av. Dr. Antônio Furlan Jr, 1028 | Sertãozinho - SP - Brasil | 14170-480

**Segurança**  
 Ex db IIB T6 Gb NCC 24.0144 ( )  
 Ex ia IIB T4/T5 Ga NCC 24.0169 X ( )  
 Tamb= -20° a 65°C (T4) -20° a 50°C (T5)  
 Ui= 30V li= 380mA Pi= 5,32W Ci= 5nF Li= desp

P1/P2 Pintura FISCO Field Device IP66W ou IP68W 10m/24h

0000000 - 0000

PROFIBUS-PA  202103





**smar IF303 Conversor 4-20mA FB**  
 Nova Smar SA Av. Dr. Antônio Furlan Jr, 1028 | Sertãozinho - SP - Brasil | 14170-480

**Segurança**  
 Ex db IIB T6 Gb NCC 24.0144 ( )  
 Ex ia IIB T4/T5 Ga NCC 24.0169 X ( )  
 Tamb= -20° a 65°C (T4) -20° a 50°C (T5)  
 Ui= 30V li= 380mA Pi= 5,32W Ci= 5nF Li= desp

P1/P2 Pintura FISCO Field Device IP66 ou IP68 10m/24h

0000000 - 0000

PROFIBUS-PA  202203





**smar IF303 Conversor 4-20mA FB**  
 Nova Smar SA Av. Dr. Antônio Furlan Jr, 1028 | Sertãozinho - SP - Brasil | 14170-480

**Segurança**  
 Ex tb IIIC T85°C Db NCC 24.0144 ( )  
 Ex ia IIIC T<sub>200</sub>135°C/T<sub>200</sub>100°C Da NCC 24.0169 X ( )  
 Tamb= -20° a 65°C (T<sub>200</sub>135°C) -20° a 50°C (T<sub>200</sub>100°C)  
 Ui= 30V li= 380mA Pi= 5,32W Ci= 5nF Li= desp

IP66 ou IP68 10m/24h

0000000 - 0000

PROFIBUS-PA  208304



FM Approvals

### NON HAZARDOUS OR DIVISION 2 AREA

SAFE AREA APPARATUS

UNSPECIFIED, EXCEPT THAT IT MUST NOT BE SUPPLIED FROM, NOR CONTAIN UNDER NORMAL OR ABNORMAL CONDITIONS, A SOURCE OF POTENTIAL IN RELATION TO EARTH IN EXCESS OF 250VAC OR 250VDC.



ASSOCIATED APPARATUS

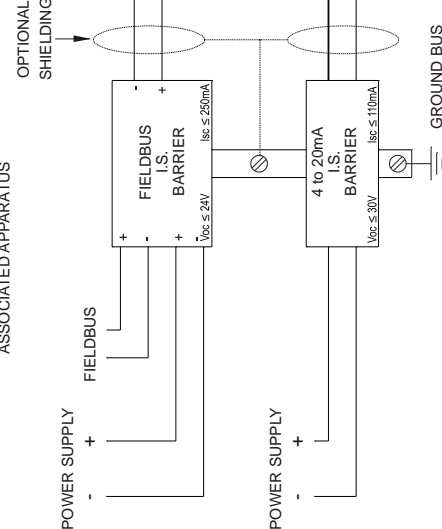

ENTITY PARAMETERS FOR ASSOCIATED APPARATUS  
CLASS I, II, III DIV 1  
GROUPS A, B, C, D, E, F & G  
Ca ≥ CABLE CAPACITANCE +5nF  
La ≥ CABLE INDUCTANCE +12uH

FIELD BUS

4-20mA  
Voc ≤ 24V  
Isc ≤ 250mA  
Po ≤ 1,2W

OPTION 1

4-20mA  
Voc ≤ 30V  
Isc ≤ 110mA

OPTION 2

4-20mA  
Voc ≤ 16V  
Isc ≤ 250mA  
Po ≤ 2W

### HAZARDOUS AREA

REQUIREMENTS:

- 1- INSTALLATION MUST BE IN ACCORDANCE WITH THE NATIONAL ELECTRICAL CODE (ANSI/NFPA 70) AND ANSI/ISA-RP12.6
- 2- TRANSMITTER SPECIFICATION MUST BE IN ACCORDANCE TO APPROVAL LISTING.
- 3- ASSOCIATED APPARATUS GROUND BUS TO BE INSULATED FROM PANELS AND MOUNTING ENCLOSURES.
- 4- ASSOCIATED APPARATUS GROUND BUS RESISTANCE TO EARTH MUST BE SMALLER THAN 1(OHME) OHM.
- 5- OBSERVE TRANSMITTER POWER SUPPLY LOAD CURVE.
- 6- WIRES: TWISTED PAIR, 22AWG OR LARGER.
- 7- SHIELD IS OPTIONAL IF USED, BE SURE TO INSULATE THE END NOT GROUNDED.
- 8- CABLE CAPACITANCE AND INDUCTANCE PLUS Ca AND La MUST BE SMALLER THAN Ca AND La OF THE ASSOCIATED APPARATUS.

FIELD BUS

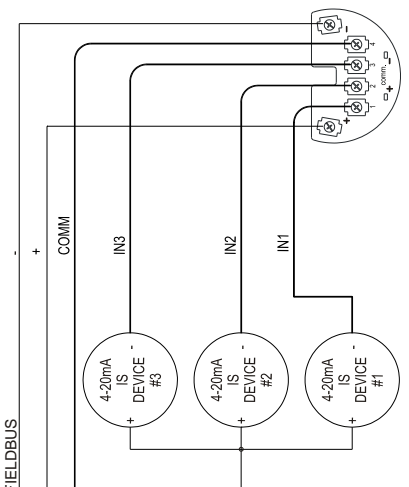

COMPONENTS CAN NOT BE SUBSTITUTED WITHOUT PREVIOUS MANUFACTURER APPROVAL.

ENTITY VALUES:  
MODELS IF302 AND IF303 - SERIES  
CLASS I, II, III DIV 1, GROUPS A, B, C, D, E, F & G

FIELD BUS

4-20mA  
Ci=5nF Li=12uH  
Vmax ≤ 24V  
Imax ≤ 250mA

APPROVAL CONTROLLED BY C.A.R.

DRAWING	DESIGN	VERIFIED	APPROVED
MELONI	M.MISSAWA	SINASTRE	PELUSO
28 / 03 / 95	28 / 03 / 95	28 / 03 / 95	28 / 03 / 95

APPROVED



smar

REV.	DESIGN	APPROVED	AREA	CONTROL DRAWING	
7	MARCIAL 20 / 10 / 08	MISSAWA 20 / 10 / 08	ALT DE 0049/08		
6	MARCIAL 16 / 07 / 07	MISSAWA 16 / 07 / 07	ALT DE 0004/07		
5	MOACIR 07 / 05 / 03	CASSIOLATO 07 / 05 / 03	ALT DE 0043/03		
4	MOACIR 08 / 02 / 00	CASSIOLATO 08 / 02 / 00	ALT DE 0015/00		

CUSTOMER:

EQUIPMENT: IF302/303

O.S.

DRAWING N. 102A0081

REV 07

SH01/01

# Appendix B



## SRF – Service Request Form

Converter from 4-20mA to Fieldbus

### GENERAL DATA

**Model:** IF302 ( ) IF303 ( )

**Serial Number:** \_\_\_\_\_

**TAG:** \_\_\_\_\_

**How many channels are used in IF?** 1 ( ) 2 ( ) 3 ( )

**Configuration:** Magnetic Tool ( ) PC ( ) Software: \_\_\_\_\_ Version: \_\_\_\_\_

### INSTALLATION DATA

**Type/Model/Manufacturer of device connected to the channel 1:** \_\_\_\_\_

**Type/Model/Manufacturer of device connected to the channel 2:** \_\_\_\_\_

**Type/Model/Manufacturer of device connected to the channel 3:** \_\_\_\_\_

### PROCESS DATA

**Hazardous Area Classification:** ( ) Yes, please specify: \_\_\_\_\_  
( ) No  
More details: \_\_\_\_\_

**Types of Interference presents in the area:** Without interference ( ) Temperature ( ) Vibration ( ) Others: \_\_\_\_\_

**Ambient Temperature:** From \_\_\_\_\_ °C up to \_\_\_\_\_ °C

### OCCURRENCE DESCRIPTION

\_\_\_\_\_  
\_\_\_\_\_  
\_\_\_\_\_  
\_\_\_\_\_

### SERVICE SUGGESTION

Adjustment ( ) Cleaning ( ) Preventive Maintenance ( ) Update / Up-grade ( )

Other: \_\_\_\_\_

### USER INFORMATION

**Company:** \_\_\_\_\_

**Contact:** \_\_\_\_\_

**Title:** \_\_\_\_\_

**Section:** \_\_\_\_\_

**Phone:** \_\_\_\_\_ **Extension:** \_\_\_\_\_

**E-mail:** \_\_\_\_\_ **Date:** \_\_\_\_/\_\_\_\_/\_\_\_\_

For warranty or non-warranty repair, please contact your representative.  
Further information about address and contacts can be found on <https://www.smar.com.br/en/contact-us>.

## ***Returning Materials***

Should it become necessary to return the converter to SMAR, simply contact your local agent or SMAR office, informing the defective instrument's serial number, and return it to our factory.

In order to expedite analysis and solution of the problem, the defective item should be returned with a description of the failure observed, with as many details as possible. Other information concerning to the instrument operation, such as service and process conditions, is also helpful.